

# A1: Thermodynamics, Kinetic Theory and Statistical Mechanics

Toby Adkins

June 20, 2016

# Contents

<b>1</b>	<b>Basic Thermodynamics</b>	<b>3</b>
1.1	Some Definitions	4
1.2	The Zeroth Law	6
1.3	The First Law	7
1.3.1	Heat Capacity	7
1.3.2	Thermodynamic Changes	9
1.3.3	The Carnot Cycle	11
1.4	The Second Law	15
1.4.1	Carnot's Theorem	15
1.4.2	Back to Clausius and Kelvin	16
1.4.3	Clausius' Theorem and Entropy	17
1.4.4	Calculating Entropy Changes	18
1.4.5	The Joule Expansion	20
1.5	Thermodynamic Relations	21
1.5.1	General Conditions for Thermodynamic Equilibrium	21
1.5.2	Thermodynamic Potentials	22
1.5.3	The Maxwell Relations	23
1.5.4	Some Useful Thermodynamic Relations	24
1.6	Thermodynamics of Other Materials	26
1.6.1	Elastic Rod	26
1.6.2	Liquid Film	27
1.6.3	Paramagnetism	28
<b>2</b>	<b>Kinetic Theory</b>	<b>30</b>
2.1	Statistical Description of a Gas	31
2.1.1	The Thermodynamic Limit	31
2.2	Distributions and Isotropy	33
2.2.1	Isotropic Distributions	33
2.2.2	The Maxwellian Distribution	34
2.3	Particle Flux	36
2.3.1	Pressure	36
2.3.2	Effusion	39
2.4	Collisions	41
2.4.1	The Characteristic Velocity	41
2.4.2	Collisions in a Mixture	42
2.5	Transport	43
2.5.1	Thermal Conductivity	43
2.5.2	Viscosity	44
2.5.3	Self-Diffusion	46
2.5.4	Heat Diffusion	47
2.6	Local Equilibrium	52

2.6.1	The Kinetic Equation	52
2.6.2	Conservation Laws	53
2.6.3	Self-Diffusion 2.0	54
<b>3</b>	<b>Statistical Mechanics</b>	<b>56</b>
3.1	Basic Principles	57
3.1.1	States of a System	57
3.1.2	Gibbs Entropy	57
3.1.3	Entropy Maximisation	58
3.1.4	Stirling's Formula	59
3.2	The Canonical Ensemble	61
3.2.1	Some Important Relationships	62
3.2.2	Stability and Equilibria	63
3.2.3	Some Common Examples	65
3.3	The Grand Canonical Ensemble	68
3.3.1	Chemical Potential	68
3.3.2	The Grand Potential	69
3.3.3	Multi-species Systems	70
3.4	The Ideal Gas	73
3.4.1	Distinguishability	73
3.4.2	Thermodynamic Quantities	74
3.4.3	Internal Degrees of Freedom	75
3.4.4	The Equipartition Theorem	76
3.4.5	With the Grand Canonical Ensemble	77
3.5	Quantum Gases	80
3.5.1	Occupation Number Statistics	80
3.5.2	Density of States	81
3.5.3	Standard Calculations	82
3.5.4	Degenerate Fermi Gas	84
3.5.5	Degenerate Bose Gas	89
3.6	The Photon Gas	94
3.6.1	Thermodynamically	94
3.6.2	As a Quantum Gas	94
<b>4</b>	<b>Further Thermodynamics</b>	<b>96</b>
4.1	Real Gases	97
4.1.1	Virial Expansion	97
4.1.2	Van-der-Waals Gas	98
4.1.3	Dieterici Gas	98
4.1.4	Critical Points	98
4.1.5	Expansions of Real Gases	100
4.2	Phase Transitions and Equilibria	103
4.2.1	Latent Heat	103
4.2.2	The Clausius-Clapeyron Equation	103

# 1. *Basic Thermodynamics*

This chapter aims to cover the basic concepts of Thermodynamics, including:

- Some Definitions
- The Zeroth Law
- The First Law
- The Second Law
- Thermodynamic Potentials
- Thermodynamics of Other Materials

Students will find that a lot of the material covered in this chapter has an almost purely experimental basis; many relations in Thermodynamics come from the results of experiment, rather than derivation from some fundamental concept, such as the value of the adiabatic constant for particular substances. This should not be a cause for alarm; in fact quite the opposite. It simply means more results that can be quoted without proof. Note that we will use  $d$  to refer to an exact differential, and  $\bar{d}$  to refer to an inexact differential.

## 1.1 Some Definitions

Before diving right into derivations and such, we need to define some concepts that will be used throughout this chapter, as follows:

- **System and Surroundings** - The 'system' is the term used to refer to the part of the Universe that we wish to examine, and the 'surroundings' are simply everything that is not this system, though it is often used to refer to the vicinity of the system. Generally, we are only interested in changes to the system, rather than the surroundings
- **Observables** - There are two main types of observables in Thermodynamics. Macroscopic observables refer to large properties of the system, such as temperature (T), volume (V) and pressure (p). Conversely, microscopic observables correspond to the properties of individual entities within the system, such as the position and velocity of all the particles within a gas. Evidently, these are much harder to determine than the macroscopic observables. We can describe the state of the system in terms of either macroscopic or microscopic observables, though evidently the former is simpler to do. For each 'macro-state' of the system (a particular combination of macroscopic observables), there may be a large number of corresponding 'micro-states'. For example, if a gas is at a particular temperature and pressure, there is a very large number of possibilities for the number of combinations of the energies and velocities of the individual particles that may create this
- **Thermodynamic Equilibrium** - This occurs where the macroscopic observables are independent of time (not changing). Macro-states are only defined in Thermodynamic equilibrium, because we cannot define the values of the macroscopic quantities when they are changing. However, the micro-states of the system are always well-defined, as they do not depend on a consideration of the average quantities of the system
- **Function of State** - These are functions of parameters  $\underline{q} = q_1, q_2, \dots, q_n$  (variables of state) that specify the state of the system. These are by definition exact differentials, such that

$$\Delta f(\underline{q}) = f(\underline{q}_f) - f(\underline{q}_i)$$

They have a well defined value in every state of thermodynamic equilibrium, independent of how the system arrived at that equilibrium. An equation of state is simply a relationship between two functions of state. The most well-known function of state (in Thermodynamics at least) is the Ideal Gas Law

$$\boxed{pV = n_m RT} \tag{1.1}$$

where  $n_m$  corresponds to the number of moles in the system, and  $R = 8.3144598 \text{ JK}^{-1}\text{mol}^{-1}$  is the universal gas constant. This means that for any ideal gas, there are only two independent variables of state

- **Ideal Gas** - This is a theoretical gas composed of many randomly moving point particles that do not interact except when they collide elastically. These two assumptions are important in deriving many results in Kinetic Theory, as supposed to Thermodynamics, but in this chapter we will only be working with ideal gases
- **Quasi-static** - A change in the system is said to be quasi-static if it is done slowly enough to preserve thermodynamic equilibrium. This means that the functions of state remain defined throughout. A good way of thinking about a quasi-static change

is as making a very large number of infinitesimal changes to the system, where each barely modifies the system, but their net effect is some overall change in the system

- Reversible - A change in the system is said to be reversible if it does not increase the entropy of the Universe (entropy will be covered as a concept more formally later).
- Isothermal - A change in the system is said to be isothermal if there is no change in temperature of the system
- Adiabatic - A change is said to be adiabatic if it is both reversible and occurs quasi-statically. This is the case when the system is thermally isolated.

As readers may have guessed, we will mostly be describing systems in terms of the macroscopic functions of state, rather than on a micro-state level; we will leave that until Chapter (3).

## 1.2 The Zeroth Law

The Zeroth Law of Thermodynamics states that

*If a system A is in thermal equilibrium with system B, and system B is in thermal equilibrium with system C, then A is in thermal equilibrium with system C*

This means that all systems must have some common property that can be used to relate them. If A is to be in thermal equilibrium with C, then they both must satisfy some function of state

$$f_{ac}(a_1, a_2, a_3, \dots, c_1, c_2, c_3, \dots)$$

Similarly, if A is to be in thermal equilibrium with B, then they both must satisfy some function of state

$$f_{bc}(b_1, b_2, b_3, \dots, c_1, c_2, c_3 \dots)$$

We can re-arrange these functions for  $c_1$  such that, for new functions  $g_{ac}$  and  $g_{bc}$ ,

$$g_{ac}(a_1, a_2, a_3, \dots, c_2, c_3 \dots) = g_{bc}(b_1, b_2, b_3, \dots, c_2, c_3 \dots) \quad (1.2)$$

We can define some function  $f_{ab}$  such that

$$f_{ab}(a_1, a_2, a_3, \dots, b_1, b_2, b_3 \dots) = 0 \quad (1.3)$$

without assuming any correspondence between the states of A and B. We should be able to arbitrarily take some of the parameters that satisfy (1.3) and substitute them into (1.2); this should not change the validity of (1.2). This means that the functions  $g_{ac}$  and  $g_{bc}$  are independent of  $c_1, c_2, \dots$ , and so we can define two new functions such that

$$\Theta_a(a_1, a_2, a_3, \dots) = \Theta_b(b_1, b_2, b_3 \dots)$$

The function  $\Theta$  is thus the property that is shared by all materials that we call temperature; a macroscopic observable that is a function of the state parameters.

A thermometer is a device used to measure the temperature of another device. They function by placing two objects in thermal contact until they both reach thermal equilibrium. Knowledge about the behaviour of the thermometer at particular temperatures, such as calibrating a column of liquid mercury against a temperature scale, can then allow us to determine the temperature of the first body. Thus, a simple alternative statement to the Zeroth Law is that 'thermometers work'.

### 1.3 The First Law

The First Law of Thermodynamics is simply a statement of energy conservation as

*Energy is conserved, and both heat and work are forms of energy*

Let  $U$  be the internal energy of the system; this can include the kinetic energy of the particles, the rotational energy, the chemical potential energy, the electrical energy, and so on. Let  $W$  be the work done on the system by some external body. Then we can write:

$$\boxed{dU = \delta Q + \delta W} \quad (1.4)$$

What is this quantity  $Q$ ? We define the differences in energy  $dU$  as the adiabatic work done to move a system from one adiabatic state to another. We can then define the quantity  $Q$  as the difference between the adiabatic work, and the actual work done on the system. We call this 'heat'; this means that heat is essentially energy in transit.

Consider an ideal gas inside a thermally isolated cylinder at some pressure  $p$ , constrained by a piston of area  $A$ . The work done to move the piston a distance  $dx$  against the pressure of the gas is

$$\begin{aligned} \delta W &= F dx \\ &= -(pA) dx \\ &= -p (Adx) \\ &= -pdV \end{aligned}$$

Assuming that this change is made gradually and not explosively, we can say that this change is reversible. Then, we can re-write (1.4) as

$$dU = \delta Q - pdV$$

It must be stressed that this last expression is for an ideal gas, and is not a universal equation; we will see other such forms of (1.4)

#### 1.3.1 Heat Capacity

The heat capacity of a system is a measure of how much heat must be supplied to it to raise the temperature of the system in order to change the temperature by  $dT$ . As such, we can write

$$\boxed{\delta Q = C dT} \quad (1.5)$$

Let us consider the internal energy to be a function of  $T$  and  $V$ , namely  $U = U(T, V)$ . Using (1.4), we can write that

$$\begin{aligned} \delta Q &= dU - \delta W \\ &= dU + pdV \\ &= \left(\frac{\partial U}{\partial T}\right)_V dT + \left(\frac{\partial U}{\partial V}\right)_T dV + pdV \end{aligned}$$

Dividing through by  $dT$ , we arrive at

$$\frac{\delta Q}{dT} = \left(\frac{\partial U}{\partial T}\right)_V + \left[\left(\frac{\partial U}{\partial V}\right)_T + p\right] \left(\frac{dV}{dT}\right) \quad (1.6)$$

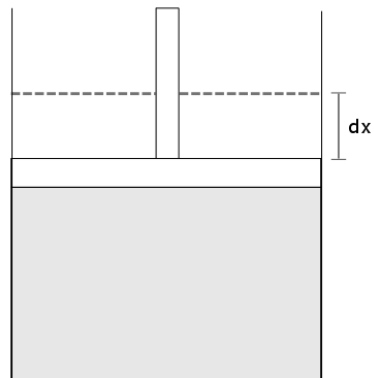

Figure 1.1: Compressing an ideal gas

At constant volume,  $dV = 0$ . The heat capacity *at constant volume* is defined as

$$C_V = \left( \frac{\partial U}{\partial T} \right)_V = T \left( \frac{\partial S}{\partial T} \right)_V \quad (1.7)$$

Similarly, at constant pressure  $dp = 0$ . The heat capacity *at constant pressure* is defined as

$$C_p = \left( \frac{\partial U}{\partial T} \right)_V + \left[ \left( \frac{\partial U}{\partial V} \right)_T + p \right] \left( \frac{\partial V}{\partial T} \right)_p = T \left( \frac{\partial S}{\partial T} \right)_p \quad (1.8)$$

Just looking at these two expressions, it is clear that generally  $C_p > C_V$ ; this means that it takes more energy to change the temperature at constant pressure than it does at constant volume.

Let us consider these quantities for an ideal gas. Suppose that the internal energy is a function of temperature only  $U = U(T)$ , such that

$$U = \frac{3}{2} n_m R T$$

We will derive this result in the chapter on Kinetic Theory. Using the Ideal Gas Law, and substituting it into the relations for  $C_p$  and  $C_V$ , we obtain

$$\begin{aligned} C_V &= \left( \frac{\partial U}{\partial T} \right)_V = \frac{3}{2} n_m R \\ C_p &= C_V + n_m R = \frac{5}{2} n_m R \end{aligned}$$

We define the *adiabatic index*  $\gamma$  as

$$\gamma = \frac{C_p}{C_V} = 1 + \frac{n_m R}{C_V} = \frac{5}{3} \quad \text{for an ideal gas} \quad (1.9)$$

This is a constant which appears a lot when considering heat changes of systems. Now that we have defined these heat capacities, we can use them to calculate the heat changes at constant pressure and volume. Re-arranging the ideal gas law for  $T$  and substituting it into (1.5), we obtain

$$dQ = \frac{C}{R} (V dp + p dV)$$

We can then either evaluate this at  $dp = 0$  or  $dV = 0$  and use the corresponding expression for the heat capacity.

*From an initial state  $(p_1, V_1)$  a gas is cooled at constant pressure to  $(p_1, V_2)$ . Then, the gas is heated at constant volume to  $(p_2, V_2)$ . Calculate the ratio of change in heat during the first process to the second.*

For this, use the formula above. The first process is at constant pressure, and so

$$\begin{aligned} Q_1 &= \frac{C_p}{R} p dV \\ &= \frac{C_p}{R} p_1 \int_{V_1}^{V_2} dV \\ &= \frac{C_p}{R} p_1 (V_2 - V_1) \end{aligned}$$

Similarly, the second process is at constant volume, so

$$\begin{aligned} Q_2 &= \frac{C_V}{R} V dp \\ &= \frac{C_V}{R} V_2 \int_{p_1}^{p_2} dp \\ &= \frac{C_V}{R} V_2 (p_2 - p_1) \end{aligned}$$

Thus, we arrive at the desired result

$$\frac{Q_1}{Q_2} = \frac{C_p}{C_V} \cdot \frac{p_1(V_1 - V_2)}{V_2(p_2 - p_1)} = \gamma \frac{(V_1/V_2) - 1}{(p_2/p_1) - 1}$$

### 1.3.2 Thermodynamic Changes

We can now examine isothermal and adiabatic processes for an ideal gas. In an isothermal process, temperature remains constant, meaning that there is no change in internal energy. Thus

$$\begin{aligned} 0 &= dQ + dW \\ dQ &= -dW \\ \Delta Q &= - \int dW \\ &= \int_{V_1}^{V_2} p dV \\ &= \int_{V_1}^{V_2} \frac{n_m R T}{V} dV \end{aligned}$$

Integrating this, we arrive at the useful expression

$$\boxed{\Delta Q = n_m R T \log \left( \frac{V_2}{V_1} \right)} \quad (1.10)$$

Now consider an adiabatic change. There is no heat exchange with the surroundings, and so  $dQ = 0$ .

$$\begin{aligned} dU &= dW \\ C_V dT &= - \frac{n_m R T}{V} dV \\ \frac{dT}{T} &= - \frac{n_m R}{C_V} \frac{dV}{V} \\ \log \left( \frac{T_2}{T_1} \right) &= - \frac{n_m R}{C_V} \log \left( \frac{V_2}{V_1} \right) \end{aligned}$$

Using the definition in (1.9) for an ideal gas, and taking the exponential of both sides, we find that

$$\boxed{TV^{\gamma-1} = \text{constant}} \quad (1.11)$$

This can be re-arranged into a few useful forms by using the Ideal Gas Law. As a little aside, we have derived this equation just by manipulation of mathematical identities; it has not really told us anything about how the gas actually behaves. The same result can be derived a little more intuitively through Kinetic Theory (see Section (2.3.1)).

From this, we can calculate the work done in an adiabatic process for an ideal gas. Suppose that a system undergoes an adiabatic process from  $p_1, V_1$  to  $p_2, V_2$ . Then, recalling that  $pV^\gamma = \text{constant}$  from Equation (1.11)

$$\Delta W_{\text{adiabatic}} = \int dV p = \int_{p_1, V_1}^{p_2, V_2} dV \frac{\text{constant}}{V^\gamma} = \left[ \text{constant} (1 - \gamma) V^{-(\gamma-1)} \right]_{p_1, V_1}^{p_2, V_2}$$

However, we can then substitute back into for the constant again such that

$$\Delta W_{\text{adiabatic}} = \left[ \frac{pV}{1 - \gamma} \right]_{p_1, V_1}^{p_2, V_2} = \frac{p_2 V_2 - p_1 V_1}{1 - \gamma}$$

### 1.3.3 The Carnot Cycle

Thermodynamic processes can be graphed in order to give us a visual understanding of the way that they operate. The most common set of axes to use for this are pressure and volume, and so diagrams of this type are often referred to as  $p$ - $V$  diagrams. On such diagrams, lines along which there is no change in pressure are called isotherms and lines along which there is no change in heat are called adiabats.

Thermodynamic processes that form a closed loop when graphed on a  $p$ - $V$  diagram are known as cycles, as they can be repeated.

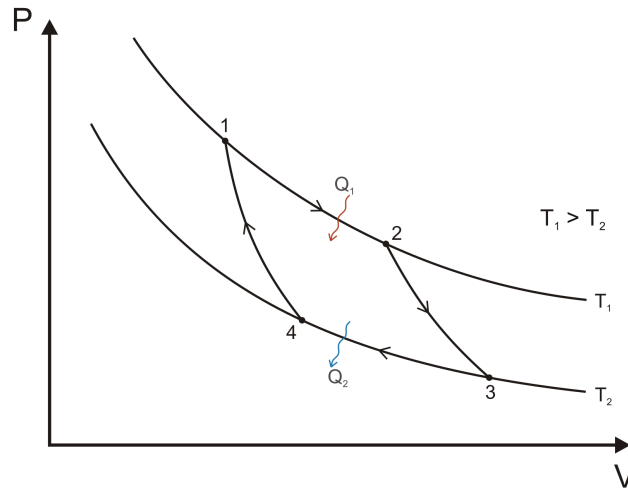

Figure 1.2: The Carnot Cycle

This is known as the Carnot Cycle. It consists of four processes:

- 1  $\rightarrow$  2: Heat  $Q_1$  is supplied to allow the isothermal expansion

$$Q_1 = n_m R T_1 \log \left( \frac{V_2}{V_1} \right)$$

- 2  $\rightarrow$  3: The system expands adiabatically

$$\frac{T_1}{T_2} = \left( \frac{V_3}{V_2} \right)^{\gamma-1}$$

- 3  $\rightarrow$  4: Heat  $Q_2$  is lost from the system as it contracts isothermally

$$Q_2 = -n_m R T_2 \log \left( \frac{V_4}{V_3} \right)$$

- 4  $\rightarrow$  1: The system contracts adiabatically

$$\frac{T_2}{T_1} = \left( \frac{V_1}{V_4} \right)^{\gamma-1}$$

Evidently, in order for energy to be conserved, the cycle has to have some output work

$$W_{\text{out}} = Q_2 - Q_1$$

In this way, we can model the Carnot Cycle as being the result of a theoretical 'Carnot Engine' with output  $W_{\text{out}}$  that is connected to two reservoirs at temperatures  $T_1$  and  $T_2$ . As the Carnot Cycle is reversible, so is the Carnot Engine. Schematically, we can represent this as in Figure (1.3). In this context, a reservoir can be thought of as a body that is sufficiently large such that we can consider to have near-infinite heat capacity; we can continue adding or removing heat, and its temperature will not change.

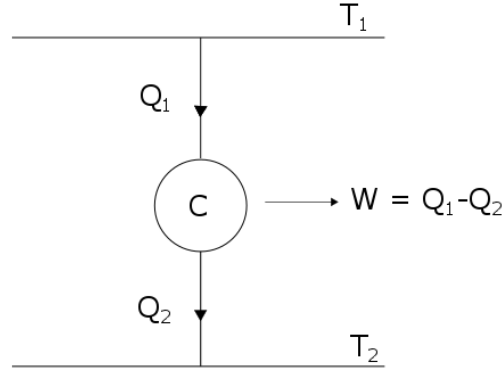

Figure 1.3: The Carnot Engine

### Efficiency

We define the efficiency of some general engine as ratio of the work done to the energy given to the system. In this case, the work done is  $W_{\text{out}}$ , while the heat supplied is  $Q_1$ . Thus, we can write the efficiency of a general heat engine is given by

$$\eta = 1 - \frac{Q_2}{Q_1}$$

In the case of the Carnot Engine, we can use the expressions on Page 9 to find that

$$\frac{V_2}{V_1} = \frac{V_3}{V_4} \rightarrow \frac{Q_2}{Q_1} = \frac{T_2}{T_1}$$

This means that our expression for the efficiency becomes

$$\boxed{\eta_c = 1 - \frac{T_2}{T_1}} \quad (1.12)$$

*A geothermal power station is proposed that will extract power from a mass  $M$  of hot rock of specific heat capacity  $C$  by cooling it from a initial temperature  $T_i$  to a final temperature  $T_f$ . The low temperature reservoir is a large river at a temperature  $T_2$ . Find an expression for the total work extracted from the engine.*

From the First Law, we have that

$$dW = \underbrace{dQ_1}_{\text{heat extracted from rock}} - \underbrace{dQ_2}_{\text{heat expelled into river}}$$

as well as the fact that  $dQ_1 = -MCdT_1$ . We shall assume that the system behaves as a Carnot engine, such that

$$\frac{dQ_1}{T_1} = \frac{dQ_2}{T_2}$$

Thus, the work obtained is given by

$$dW = -MCdT_1 - \frac{T_2}{T_1}dQ_1 = -MCdT_1 \left(1 - \frac{T_2}{T_1}\right)$$

Integrating, it follows that the final expression for the work done is

$$\Delta W = -MC(T_f - T_i) + MCT_2 \log\left(\frac{T_f}{T_i}\right)$$

### Carnot Engines in Reverse

One type of application of heat engines is where the engine is run in reverse, requiring the input of work in order to move heat around. As we will see, in order for an engine to be reversible, it must be a Carnot Engine.

- Refrigerator - This moves heat from a cooler body to a hotter body. As such, efficiency is given by the amount of heat that can be extracted for the amount of work done. As such, we define efficiency in this case as

$$\eta = \frac{Q_\ell}{W}$$

where  $Q_\ell$  is the heat taken from the lower body. As it must be Carnot Engine, we find that

$$\eta = \frac{T_\ell}{T_h - T_\ell} \quad (1.13)$$

where  $T_\ell$  is the temperature of the cooler body, and  $T_h$  is the temperature of the hotter body.

- Heat Pump - Conversely, this moves heat from a hotter reservoir to somewhere else desired. Suppose that we want to add  $Q_h$  to the second body. The work done to accomplish this is again  $W$ , and so the efficiency is

$$\eta = \frac{Q_h}{W}$$

Again using the fact that it must be a Carnot Engine, it follows that

$$\eta = \frac{T_h}{T_h - T_\ell} \quad (1.14)$$

In both cases, the efficiency may achieve values greater than unity (this *has* to be the for the heat pump as  $Q_h < W$  in order to conserve energy), which is why they are such attractive methods for moving heat around.

*A building is maintained at a temperature  $T$  by means of an ideal heat pump which uses a river at temperature  $T_0$  as a source of heat. The heat pump consumes power  $W$ , and the building loses heat to its surroundings at a rate  $\alpha(T - T_0)$ . Find an expression for  $T$  in the steady state.*

Using (1.14), we can immediately write

$$\eta = \frac{T}{T - T_0}$$

When the house reaches steady state (i.e a stable temperature), the rate of heat loss to the surroundings has to be equal to the output heat of the pump. Thus,

$$\begin{aligned}\alpha(T - T_0) &= \eta W \\ &= \frac{T}{T - T_0} W \\ WT &= \alpha(T - T_0)^2\end{aligned}$$

Solving this quadratic for  $T$ , we obtain

$$T = T_0 + \frac{W}{2\alpha} \left( 1 + \sqrt{1 + \frac{4\alpha T_0}{W}} \right)$$

## 1.4 The Second Law

Let us begin by considering two alternative statements of the Second Law of Thermodynamics.

*Clausius' Statement: No process is possible whose sole result is the transfer of heat from a colder body to a hotter body*

or

*Kelvin's Statement: No process is possible whose sole result is the complete conversion of heat into work*

We will show that these are equivalent, but we first need to prove a very important result.

### 1.4.1 Carnot's Theorem

Carnot's Theorem states that

*No engine operating between two temperature reservoirs can be more efficient than the Carnot Engine*

That is, the most efficient engine is the Carnot Engine. Let us prove this by supposing that we could great an engine E that was more efficient than the Carnot Engine C. Run E between two reservoirs at temperatures  $T_1$  and  $T_2$  such that it's output work powers C in reverse, as shown below.

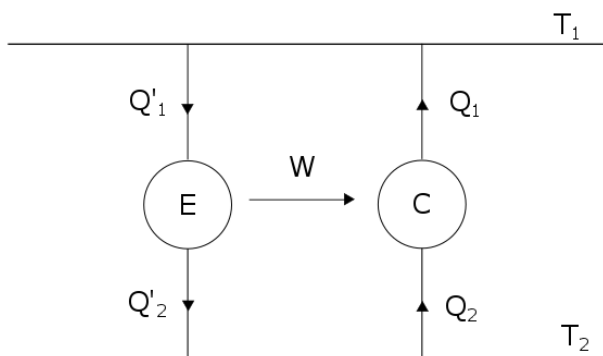

Figure 1.4: The engine E and a Carnot engine C run in reverse

By the original assumption, we have that  $\eta_e > \eta_c$ . Then

$$\begin{aligned} \frac{W}{Q'_1} &> \frac{W}{Q_1} \\ Q_1 &> Q'_1 \end{aligned}$$

The First Law of Thermodynamics implies that

$$\begin{aligned} W &= Q'_1 - Q'_2 = Q_1 - Q_2 \\ Q_1 - Q'_1 &= Q'_2 - Q_2 \end{aligned}$$

Both sides of this expression are positive, and so this means that the combined system does no work to take heat from  $T_2$  and dump it in  $T_1$ , which violates Clausius's statement of the Second Law. Thus, *reductio ad absurdum*, we have shown the result.

An interesting corollary of this theorem is the statement that

*All reversible engines have the same efficiency equal to that of the Carnot Engine*

Consider a reversible engine R such that  $\eta_r < \eta_c$ . Connect it to a Carnot Engine as shown below.

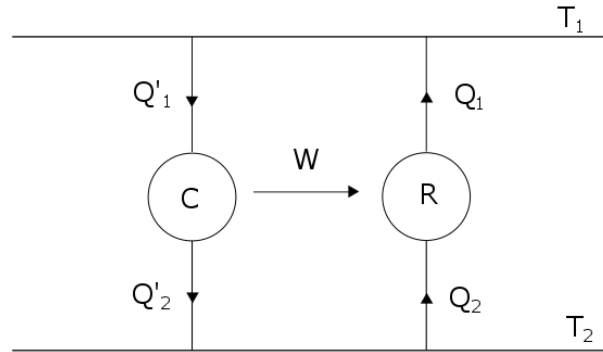

Figure 1.5: A Carnot Engine C and a reversible engine R run in reverse

From the First Law of Thermodynamics,

$$\begin{aligned} Q'_2 &= Q'_1 - W \\ Q_2 &= Q_1 - W \end{aligned}$$

Now use our original assumption that

$$\begin{aligned} \eta_r &< \eta_c \\ 1 - \frac{Q_2}{Q_1} &< 1 - \frac{Q'_2}{Q'_1} \\ \frac{W}{Q_1} &< \frac{W}{Q'_1} \\ Q'_1 &< Q_1 \end{aligned}$$

But this contradicts Clausius' statement, and so the result follows.

#### 1.4.2 Back to Clausius and Kelvin

We can now show that Clausius' and Kelvin's statements are equivalent. First, consider a hypothetical engine K that violates Kelvin's statement (converting all heat into work) and use it to drive a Carnot Engine in reverse. Then by the First Law of Thermodynamics

$$\begin{aligned} W &= Q'_1 \\ Q_2 &= Q_1 - W \end{aligned}$$

The net heat flowing from the combined engine into  $T_1$  is thus

$$Q_1 - Q'_1 = Q_2$$

This means that heat is flowing directly from the cooler reservoir into the hotter reservoir ( $T_1 > T_2$ ), violating Clausius' statement. Thus, Kelvin's statement implies Clausius' statement.

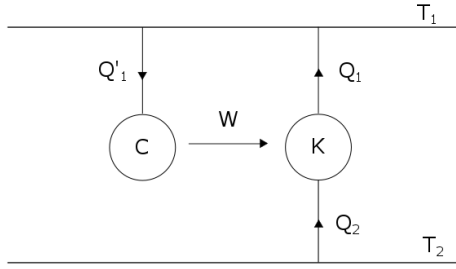

Figure 1.6: A hypothetical 'Kelvin violator' powering a Carnot Engine in reverse

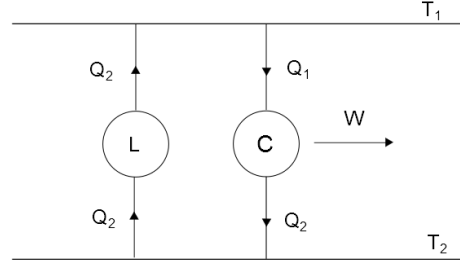

Figure 1.7: A hypothetical 'Clausius violator' connected to a Carnot Engine

We still have to prove the reverse case. Consider an engine L that violates Clausius' statement and connect to a Carnot engine as shown in Figure (1.7). Consider the net heat flows in and out of the engine.

$$\begin{aligned} Q_{\text{in}} &= Q_1 - Q_2 \\ Q_{\text{out}} &= Q_2 - Q_2 = 0 \end{aligned}$$

This means that the net effect is the conversion of heat completely into work, violating Kelvin's statement. We have thus shown that the statements are completely equivalent.

### 1.4.3 Clausius' Theorem and Entropy

Clausius' Theorem states that for a system at constant temperature  $T$

$$\oint \frac{dQ}{T} \leq 0 \quad (1.15)$$

where the equality sign applies when the change is reversible. The proof of this is a little tedious, so it will not be covered here. In the case where the equality applies, we know that the integrand must be an exact differential. We thus define

$$dS = \frac{dQ_{\text{rev}}}{T}$$

This function of state is known as the entropy of the system, and is in a sense a measure of the 'disorder' of the system at a particular temperature. Consider (1.15).

$$\begin{aligned} \oint \frac{dQ}{T} &\leq 0 \\ \int_a^b \frac{dQ}{T} + \int_b^a \frac{dQ_{\text{rev}}}{T} &\leq 0 \\ \int_a^b \frac{dQ}{T} &\leq \int_a^b \frac{dQ_{\text{rev}}}{T} \\ \frac{dQ}{T} &\leq \frac{dQ_{\text{rev}}}{T}; \end{aligned}$$

This means we can write

$$dS = \frac{dQ_{\text{rev}}}{T} \geq \frac{dQ}{T} \quad (1.16)$$

If a system is thermally isolated,  $dQ = 0$ , meaning that  $dS \geq 0$ . This leads to a more universal statement of The Second Law of Thermodynamics as

*For any thermally isolated system, the entropy must either stay the same or increase:  $dS \geq 0$*

This is often stated as 'the entropy of the Universe must increase' as this is technically true; if we consider the Universe as a thermally isolated system, its entropy can do nothing but increase (as there are no truly adiabatic processes).

For a reversible change,  $dQ = TdS$ . This means we can re-write the First Law of Thermodynamics as

$$\boxed{dU = TdS - pdV} \quad (1.17)$$

Even though we have proven it using results for reversible changes, this equation turns out to be always true; for an irreversible change,  $dQ \leq TdS$  but  $dW \geq -pdV$ , meaning that  $dU$  remains the same regardless of the reversibility of the process. For an adiabatic process, the total change in entropy is zero as  $dQ = 0$  by definition. However, this is not the case for isothermal processes.

#### 1.4.4 Calculating Entropy Changes

Consider a large reservoir at temperature  $T_r$  that is placed in thermal contact with a smaller system at temperature  $T_s$  that has heat capacity  $C$  that is independent of temperature. As the reservoir remains at constant temperature, its change in entropy is given by

$$\begin{aligned} \Delta S_r &= \int \frac{dQ_{\text{rev}}}{T_r} \\ &= \frac{1}{T_r} \int dQ_{\text{rev}} \\ &= \frac{1}{T_r} C(T_s - T_r) \end{aligned}$$

This is because we assume that the bodies will reach thermodynamic equilibrium, and we have used (1.5). Thus,

$$\boxed{\Delta S_r = C \left( \frac{T_s}{T_r} - 1 \right)} \quad (1.18)$$

Similarly for the system

$$\begin{aligned} \Delta S_s &= \int \frac{dQ_{\text{rev}}}{T} \\ &= \int \frac{d(CT)}{T} \\ &= C \int \frac{dT}{T} \end{aligned}$$

using (1.5) again. Thus,

$$\boxed{\Delta S_s = C \log \left( \frac{T_r}{T_s} \right)} \quad (1.19)$$

The change in entropy of the Universe,  $\Delta S_u$ , is simply the sum of both of these terms.

Initially, a cube of heat capacity  $C$  is cooled from an initial temperature  $T_a$  to a final temperature  $T_b$  using a heat-bath at temperature  $T_b$ . For  $T_a > T_b$ , find the ratio of  $T_a$  to  $T_b$  that allows the total entropy change to vanish in the limit where an infinite number of intermediate baths are used.

If in the interval  $T_a - T_b$  there are  $n$  baths, then each bath creates a temperature change of  $(T_a - T_b)/n$ . Consider the  $i^{\text{th}}$  bath. The temperature at which we evaluate the bath is given by

$$T_i = T_a - i \left( \frac{T_a - T_b}{n} \right)$$

The total change in entropy for the baths is thus

$$\begin{aligned} \Delta S_b &= C \frac{T_a - T_b}{n} \sum_{i=1}^n \frac{1}{T_a - i \left( \frac{T_a - T_b}{n} \right)} \\ &= C \sum_{i=1}^n \frac{1}{\frac{T_a}{T_a - T_b} n - i} \\ &= C \sum_{i=1}^n \frac{1}{Rn - i} \end{aligned}$$

We have let  $R = T_a/(T_a - T_b)$ . Now let  $j = Rn - i$ .

$$\begin{aligned} \Delta S_b &= C \sum_{j=n}^{Rn-1} \frac{1}{j} \\ &\approx C \log \left( \frac{Rn - 1}{n} \right) \\ &= C \log \left( R - \frac{1}{n} \right) \end{aligned}$$

Now, the change in entropy of the cube is always the same, regardless of the value of  $n$ .

$$\Delta S_c = C \log \left( \frac{T_b}{T_a} \right) = C \log \left( 1 - \frac{1}{R} \right)$$

Thus, the total entropy change is given by in the limit as  $n \rightarrow \infty$  is

$$\begin{aligned} \Delta S_u &= \lim_{n \rightarrow \infty} \Delta S_b + \Delta S_c \\ &= \lim_{n \rightarrow \infty} C \log \left( R - \frac{1}{n} \right) + C \log \left( 1 - \frac{1}{R} \right) \\ &= C \log(R - 1) \end{aligned}$$

This means that we require  $R = 2$  for the entropy to vanish.

$$\begin{aligned} \frac{T_a}{T_a - T_b} &= 2 \\ T_a &= 2T_a - 2T_b \\ T_a &= 2T_b \end{aligned}$$

This means that the ratio that we require for the entropy to vanish is  $T_a/T_b = 2$ , such as  $T_a = 200K$  and  $T_b = 100K$ .

### The Entropy of an Ideal Gas

Here we want to calculate the entropy of an arbitrary number ( $n_m$ ) of moles of an ideal gas. Consider entropy as a function of  $T$  and  $V$ .

$$\begin{aligned} dS &= \left(\frac{\partial S}{\partial T}\right)_V dT + \left(\frac{\partial S}{\partial V}\right)_T dV \\ &= \frac{C_V}{T} dT + \left(\frac{\partial p}{\partial T}\right)_V dV \end{aligned}$$

Here we have used (1.31). For an ideal gas, we have that

$$\left(\frac{\partial p}{\partial T}\right)_V = \frac{n_m R}{V}$$

Integrating  $dS$ , we thus find that

$$\boxed{S = C_V \log(T) + n_m R \log(V) + \text{constant}} \quad (1.20)$$

Thus, the entropy of an idea gas increases with both  $T$  and  $V$ .

#### 1.4.5 The Joule Expansion

Consider two containers A and B of volumes  $V_a$  and  $V_b$  respectively that are connected by a tap. Initially, container A is filled with one mole of ideal gas at  $p_i$  and  $T_i$ . We now pose the question; if the system is thermally isolated, what is the change of entropy when the tap is opened (assuming no work is done to open the tap)?

As the system is thermally isolated,  $dQ = 0$ . There is also no work done, which implies  $dW = 0$ . This means that there can be no change in temperature as  $dU(T) = 0$ .

$$\begin{aligned} dU &= TdS + dW \\ 0 &= TdS - pdV \\ dS &= \frac{pdV}{T} = \frac{RdV}{V} \end{aligned}$$

This means we find that the entropy of the expansion is

$$\Delta S = R \log\left(\frac{V_f}{V_i}\right)$$

The only way to get the gas back into chamber A is to compress it. The best way to do this, or rather the way that requires the least work, is via a reversible isothermal compression.

$$\Delta W = - \int_{V_f}^{V_i} p dV = - \int_{V_f}^{V_i} \frac{RT}{V} dV = RT \log\left(\frac{V_f}{V_i}\right)$$

This means that for The Joule Expansion, the entropy change is simply

$$\boxed{\Delta S = \frac{\Delta W}{T}} \quad (1.21)$$

## 1.5 Thermodynamic Relations

Before diving into the material for this section, it would be useful to recall two important results from partial calculus. Consider a function  $z = f(x, y)$ . We can write

$$dz = \left(\frac{\partial z}{\partial x}\right)_y dx + \left(\frac{\partial z}{\partial y}\right)_x dy$$

and

$$dy = \left(\frac{\partial y}{\partial x}\right)_z dx + \left(\frac{\partial y}{\partial z}\right)_x dz$$

Substituting the second of these into the first:

$$dz = \left(\frac{\partial z}{\partial x}\right)_y dx + \left[\left(\frac{\partial z}{\partial y}\right)_x \left(\frac{\partial y}{\partial x}\right)_z + \left(\frac{\partial z}{\partial z}\right)_x\right] dx$$

For  $dz = 0$ , we find the *reciprocity relation*

$$\left(\frac{\partial y}{\partial x}\right)_z = \left(\frac{\partial x}{\partial y}\right)_z^{-1} \quad (1.22)$$

Now for  $dx = 0$ , we obtain the *cyclic relation*

$$\left(\frac{\partial x}{\partial y}\right)_z \left(\frac{\partial y}{\partial z}\right)_x \left(\frac{\partial z}{\partial x}\right)_y = -1 \quad (1.23)$$

We will use these extensively when manipulating partial derivatives in this section.

### 1.5.1 General Conditions for Thermodynamic Equilibrium

Consider a system in contact with surroundings that are at  $T_o$  and  $p_o$ . The surroundings will do work  $dW$  and transfer  $dQ$  to the system. Calculating the change in entropy of the surroundings as the system comes to thermal equilibrium:

$$\begin{aligned} dU_o &= -dU = T_o dS_o - p_o(-dV) \\ dS_o &= -\left(\frac{dU + p_o dV}{T_o}\right) \end{aligned}$$

The entropy change in the Universe is thus

$$\begin{aligned} dS_u &= dS_o + dS \geq 0 \\ T_o dS_u &= -(dU + p_o dV - T_o dS) \end{aligned}$$

As  $p_o$  and  $T_o$  are constants, we define the *availability*  $A$

$$dA = dU + p_o dV - T_o dS \quad (1.24)$$

such that

$$dA \leq 0$$

in equilibrium.  $A$  will decrease as the system goes towards equilibrium, and so equilibrium will be reached when  $A$  is minimised.

### 1.5.2 Thermodynamic Potentials

Thermodynamic potentials are scalar quantities used to represent the thermodynamic state of a system. They are total differentials as they are functions of state.

#### Internal Energy

*Internal Energy*  $U(S, V)$  is defined as

$$\boxed{dU = TdS - pdV} \quad (1.25)$$

- It has natural variables  $S$  and  $V$ . It follows that

$$T = \left( \frac{\partial U}{\partial S} \right)_V \quad \text{and} \quad p = - \left( \frac{\partial U}{\partial V} \right)_S$$

- Internal energy corresponds to the heat absorbed by the system under isochoric (constant  $V$ ) expansion:  $dU = C_V dT$
- If a system is thermally isolated at a fixed volume,  $dA = dU$ . Equilibrium will be reached when the internal energy of the system is minimised

#### Enthalpy

The *enthalpy*  $H(S, p)$  is defined as

$$\boxed{H = U + pV} \quad (1.26)$$

- It has natural variables  $S$  and  $p$ . It has the explicit form of

$$\begin{aligned} dH &= dU + pdV + Vdp \\ &= TdS - pdV + pdV + Vdp \\ dH &= TdS + Vdp \end{aligned}$$

It follows that

$$T = \left( \frac{\partial H}{\partial S} \right)_p \quad \text{and} \quad V = - \left( \frac{\partial H}{\partial p} \right)_S$$

- Enthalpy corresponds to the heat absorbed by a system in an isobaric (constant  $p$ ) process:  $dH = C_p dT$ . For example, if a chemical reaction is exothermic,  $dH < 0$
- If a system is thermally isolated with fixed pressure,  $dA = dH$ . Equilibrium will be reached when the enthalpy of the system is minimised

#### Helmholtz Free Energy

The *Helmholtz Free Energy*  $F(V, T)$  of a system is defined as

$$\boxed{F = U - TS} \quad (1.27)$$

- It has natural variables  $V$  and  $T$ . It has the explicit form of

$$\begin{aligned} dF &= dU - SdT - TdS \\ &= TdS - pdV - SdT - TdS \\ dF &= -pdV - SdT \end{aligned}$$

It follows that

$$p = - \left( \frac{\partial F}{\partial V} \right)_T \quad \text{and} \quad S = - \left( \frac{\partial F}{\partial T} \right)_V$$

- The Helmholtz Free Energy corresponds to the maximal amount of work that the system can do in an isothermal (constant  $T$ ) process:  $dF = -pdV$ . If  $dF > 0$ , then work is done on the system by the surroundings
- If a system has a fixed temperature and volume, then  $dA = dF$ . Equilibrium will be reached when the Helmholtz function is minimised

### Gibbs Free Energy

The *Gibbs Free Energy*  $G(T, p)$  of a system is defined as

$$\boxed{G = U - TS + pV} \quad (1.28)$$

- It has natural variables  $T$  and  $p$ . It has the explicit form of

$$\begin{aligned} dG &= dU - TdS - SdT + pdV + Vdp \\ &= TdS - pdV + pdV - TdS + Vdp - SdT \\ dG &= Vdp - SdT \end{aligned}$$

It follows that

$$V = \left( \frac{\partial G}{\partial p} \right)_T \quad \text{and} \quad S = - \left( \frac{\partial G}{\partial T} \right)_p$$

- For a system undergoing processes at constant  $T$  and  $p$ ,  $dG = 0$ . This means that the Gibbs function is conserved in any phase transition under these constraints
- If a system has a fixed temperature and pressure, the  $dA = dG$ . Equilibrium will be reached when the Gibbs function is minimised

### 1.5.3 The Maxwell Relations

The so called *Maxwell Relations* are derived from the fact that the thermodynamic potentials are total differentials. This means that for some general function

$$df = Adx + Bdy \longrightarrow \frac{\partial A}{\partial y} = \frac{\partial B}{\partial x}$$

Considering the thermodynamic potentials:

- Internal Energy -  $dU = TdS - pdV$

$$\boxed{\left( \frac{\partial T}{\partial V} \right)_S = - \left( \frac{\partial p}{\partial S} \right)_V} \quad (1.29)$$

- Enthalpy -  $dH = TdS + Vdp$

$$\boxed{\left( \frac{\partial T}{\partial p} \right)_S = \left( \frac{\partial V}{\partial S} \right)_p} \quad (1.30)$$

- Helmholtz Free Energy -  $dF = -SdT - pdV$

$$\boxed{\left( \frac{\partial S}{\partial V} \right)_T = \left( \frac{\partial p}{\partial T} \right)_V} \quad (1.31)$$

- Gibbs Free Energy -  $dG = Vdp - SdT$

$$\boxed{\left( \frac{\partial S}{\partial p} \right)_T = - \left( \frac{\partial V}{\partial T} \right)_p} \quad (1.32)$$

### 1.5.4 Some Useful Thermodynamic Relations

We can use these thermodynamic potentials to derive some very useful thermodynamic relations.

1. Consider  $S(T, V)$

$$\begin{aligned} dS &= \left(\frac{\partial S}{\partial T}\right)_V dT + \left(\frac{\partial S}{\partial V}\right)_T dV \\ &= \left(\frac{\partial S}{\partial T}\right)_V dT + \left(\frac{\partial p}{\partial T}\right)_V dV \end{aligned}$$

from (1.31). Let  $dS = 0$ :

$$\begin{aligned} -\left(\frac{\partial S}{\partial T}\right)_V dT &= \left(\frac{\partial p}{\partial T}\right)_V dV \\ \left(\frac{\partial T}{\partial V}\right)_S &= -\left(\frac{\partial p}{\partial T}\right)_V \left(\frac{\partial S}{\partial T}\right)_V^{-1} \end{aligned}$$

Recall (1.7). Then:

$$\boxed{\left(\frac{\partial T}{\partial V}\right)_S = -\frac{T}{C_V} \left(\frac{\partial p}{\partial T}\right)_V} \quad (1.33)$$

This is appropriate for an adiabatic or isentropic (at constant entropy) as there is no change in entropy. This can be used to derive (1.11) if the Ideal Gas Law is considered

2. Consider  $U(T, V)$

$$\begin{aligned} dU &= \left(\frac{\partial U}{\partial T}\right)_V dT + \left(\frac{\partial U}{\partial V}\right)_T dV \\ &= C_V dT + \left(\frac{\partial U}{\partial V}\right)_T dV \end{aligned}$$

Using the First Law of Thermodynamics, and substituting the result for  $dS$  from above

$$\begin{aligned} dU &= TdS - pdV \\ C_V dT + \left(\frac{\partial U}{\partial V}\right)_T dV &= T \left[ \left(\frac{\partial S}{\partial T}\right)_V dT + \left(\frac{\partial p}{\partial T}\right)_V dV \right] - pdV \end{aligned}$$

Let  $dT = 0$

$$\begin{aligned} \left(\frac{\partial U}{\partial V}\right)_T &= T \left(\frac{\partial p}{\partial T}\right)_V - p \\ dU &= C_V dT + \left[ T \left(\frac{\partial p}{\partial T}\right)_V - p \right] dV \end{aligned}$$

Now, letting  $dU = 0$ , and re-arranging, we arrive at

$$\boxed{\left(\frac{\partial T}{\partial V}\right)_U = -\frac{1}{C_V} \left[ T \left(\frac{\partial p}{\partial T}\right)_V - p \right]} \quad (1.34)$$

This is appropriate for an isothermal expansion as there is no change in the internal energy

3. Consider  $H(T, p)$

$$\begin{aligned} dH &= \left(\frac{\partial H}{\partial T}\right)_p dT + \left(\frac{\partial H}{\partial p}\right)_T dp \\ &= C_p dT + \left(\frac{\partial H}{\partial p}\right)_T dp \\ dS &= \left(\frac{\partial S}{\partial T}\right)_p dT - \left(\frac{\partial V}{\partial T}\right)_p dp \end{aligned}$$

using (1.32). Substitute these into the explicit form of  $dH$

$$\begin{aligned} C_p dT + \left(\frac{\partial H}{\partial p}\right)_T dp &= \left(\frac{\partial S}{\partial T}\right)_p dT - \left(\frac{\partial V}{\partial T}\right)_p dp + V dp \\ dp \left[ \left(\frac{\partial H}{\partial p}\right)_T + T \left(\frac{\partial V}{\partial T}\right)_p - V \right] &= dT \left[ T \left(\frac{\partial S}{\partial T}\right)_p - C_p \right] \end{aligned}$$

Let  $dT = 0$

$$\begin{aligned} \left(\frac{\partial H}{\partial p}\right)_T &= V - T \left(\frac{\partial V}{\partial T}\right)_p \\ dH &= C_p dT + \left[ V - T \left(\frac{\partial V}{\partial T}\right)_p \right] dp \end{aligned}$$

Letting  $dH = 0$ , and re-arranging, we arrive at

$$\boxed{\left(\frac{\partial T}{\partial p}\right)_H = \frac{1}{C_p} \left[ T \left(\frac{\partial V}{\partial T}\right)_p - V \right]} \quad (1.35)$$

This is appropriate for a reversible isothermal expansion as it occurs at constant  $H$ .

4. Consider  $S(T, V)$

$$\begin{aligned} dS &= \left(\frac{\partial S}{\partial T}\right)_V dT + \left(\frac{\partial S}{\partial V}\right)_T dV \\ \left(\frac{\partial S}{\partial T}\right)_p &= \left(\frac{\partial S}{\partial T}\right)_V + \left(\frac{\partial S}{\partial V}\right)_T \left(\frac{\partial V}{\partial T}\right)_p \\ \frac{C_p}{T} &= \frac{C_V}{T} + \left(\frac{\partial S}{\partial V}\right)_T \left(\frac{\partial V}{\partial T}\right)_p \end{aligned}$$

Using (1.31) and a cyclical differential identity:

$$\left(\frac{\partial S}{\partial V}\right)_T = \left(\frac{\partial p}{\partial T}\right)_V = - \left(\frac{\partial p}{\partial V}\right)_T \left(\frac{\partial V}{\partial T}\right)_p$$

Substituting this in, and using the known definitions of  $\beta_p$  and  $\kappa_T$ , we arrive at

$$\boxed{C_p - C_V = \frac{VT\beta_p^2}{\kappa_T}} \quad (1.36)$$

## 1.6 Thermodynamics of Other Materials

Up until this point, we have just considered Ideal Gases, writing the First Law of Thermodynamics in a particular form, and deriving many results from this. However, the relevant thermodynamic concepts can be extended to systems other than Ideal Gases. Instead of writing  $dW = -pdV$ , we write

$$dW = X dx \quad (1.37)$$

where  $X$  is some intensive (do not depend on system size), generalised force, and  $dx$  is some extensive (depend on system size), generalised displacement. Some examples include

	$X$	$x$
fluid	pressure ( $-p$ )	volume ( $V$ )
elastic rod	tension ( $f$ )	length ( $L$ )
liquid film	surface tension ( $\gamma$ )	surface area ( $A$ )
dielectric	electric field ( $\underline{E}$ )	polarisation ( $\underline{p}$ )
magnetic	magnetic field ( $\underline{B}$ )	magnetisation ( $\underline{m}$ )

In these more general cases, we define the heat capacity at constant 'blah' by

$$C_{\text{blah}} = T \left( \frac{\partial S}{\partial T} \right)_{\text{blah}} \quad (1.38)$$

The following sections detail some examples of applying these thermodynamic concepts to these generalised cases. Do not forget the thermodynamic relations, particularly the Helmholtz free energy in isothermal calculations involving entropy.

### 1.6.1 Elastic Rod

The equation of state for an elastic rod is

$$dU = TdS + fdL \quad (1.39)$$

Young's isothermal modulus is defined as the ratio of the stress  $\sigma$  to the strain  $\varepsilon$ .

$$\begin{aligned} \sigma &= \frac{df}{A} \\ \varepsilon &= \frac{dL}{L} \\ \rightarrow E_T &= \frac{\sigma}{\varepsilon} = \frac{L}{A} \left( \frac{\partial f}{\partial L} \right)_L \end{aligned}$$

The linear expansiveness at constant tension is give by

$$\alpha_f = \frac{1}{L} \left( \frac{\partial L}{\partial T} \right)_f$$

We can investigate some properties of the material.

- Adiabatic Stretching - Suppose that we increase the length without a change in entropy, what is the response of the system?

$$dQ = 0$$

$$dU = dW$$

$$C_T dT = f dL$$

Thus, as  $C_T > 0$ ,  $f > 0$ , meaning that for an increase in length, temperature will also increase

- Contraction under constant  $f$  - If we warm the band under constant tension, it will contract. Using the reciprocity relation

$$\begin{aligned} \left(\frac{\partial L}{\partial T}\right)_f \left(\frac{\partial f}{\partial L}\right)_T \left(\frac{\partial T}{\partial f}\right)_L &= -1 \\ \left(\frac{\partial L}{\partial T}\right)_f &= -\left(\frac{\partial f}{\partial T}\right)_L \left(\frac{\partial L}{\partial f}\right)_T \\ \alpha_f &= -\frac{1}{AE_T} \left(\frac{\partial f}{\partial T}\right)_L \end{aligned}$$

Now if we assume that the tension  $f$  is proportional to the temperature  $T$  if the length  $L$  is held constant, then clearly  $\alpha_f < 0$ . This means it will contract

- Entropy changes under stretching - How does the entropy change under stretching? Again using a reciprocity relation

$$\begin{aligned} \left(\frac{\partial f}{\partial T}\right)_L &= -\left(\frac{\partial f}{\partial L}\right)_T \left(\frac{\partial L}{\partial T}\right)_S \\ &= -AE_T \alpha_f \end{aligned}$$

From the Helmholtz function,

$$S = -\left(\frac{\partial F}{\partial T}\right)_L \quad \text{and} \quad f = \left(\frac{\partial F}{\partial L}\right)_T$$

This means that

$$\Delta Q = T\Delta S = \alpha_f AE_T T \Delta L$$

Stretching the rod increases entropy if  $\alpha_f > 0$  for the substance. Let us consider the case of a metallic wire. This contains many small crystallites which have low entropy. The action of stretching the wire distorts those small crystallites, and that increases their entropy and so heat is absorbed. However, for materials like rubber  $\alpha_f < 0$ , and hence an isothermal extension means that heat is emitted. The action of stretching a piece of rubber at constant temperature results in the alignment of the long rubber molecules that are initially bunched, reducing their entropy and causing heat to be released.

### 1.6.2 Liquid Film

In this case, the equation of state for the internal energy is given by:

$$\boxed{dU = TdS + \gamma dA}$$

From the Helmholtz free energy,

$$\begin{aligned} dF &= -SdT + \gamma dA \\ \left(\frac{\partial S}{\partial A}\right)_T &= -\left(\frac{\partial \gamma}{\partial T}\right)_A \end{aligned}$$

*Consider the case where a cloud of droplets condenses isothermally to form a single droplet. What is the change in temperature?*

$$\begin{aligned} dU &= TdS + \gamma dA = 0 \\ T \left[ \left(\frac{\partial S}{\partial A}\right)_T dA + \left(\frac{\partial S}{\partial T}\right)_A dT \right] + \gamma dA &= 0 \\ T \left(\frac{\partial S}{\partial A}\right)_T + c_p M dT + \gamma dA &= 0 \end{aligned}$$

Re-arranging, we can find an expression for the change in temperature:

$$\begin{aligned} c_p M dT &= - \left( T \left( \frac{\partial S}{\partial A} \right)_T + \gamma \right) dA \\ c_p M dT &= - \left( \frac{\partial U}{\partial A} \right)_T dA \\ \Delta T &= - \frac{\Delta A}{c_p M} \left( \frac{\partial U}{\partial A} \right)_T \end{aligned}$$

The change in entropy can simply be calculated from

$$\begin{aligned} \Delta S &\approx \left( \frac{\partial S}{\partial A} \right)_T \Delta A \\ \left( \frac{\partial S}{\partial A} \right)_T &= \frac{1}{T} \left[ \left( \frac{\partial U}{\partial A} \right)_T - \gamma \right] = - \left( \frac{\partial \gamma}{\partial T} \right)_A \\ \Delta S &= \frac{\Delta A}{T} \left[ \left( \frac{\partial U}{\partial A} \right)_T - \gamma \right] \end{aligned}$$

### 1.6.3 Paramagnetism

Paramagnetic materials are those that obtain a magnetisation  $M$  in a magnetic field, giving them a magnetic moment  $m = MV$  for  $M = \chi_m B / \mu_o$ . We define the magnetic susceptibility as

$$\chi_m = \lim_{H \rightarrow 0} \frac{M}{H} = \frac{C}{T} \quad (1.40)$$

This means that  $\chi$  obeys Curie's inverse law. The equation of state for the internal energy is

$$\boxed{dU = TdS + \underline{B} \cdot d\underline{m}} \quad (1.41)$$

Note that for paramagnetic materials, it is useful to include the magnetic energy in the Helmholtz free energy, given by

$$\begin{aligned} F &= U - TS - \underline{m} \cdot \underline{B} \\ \rightarrow dF &= -SdT - \underline{m} \cdot d\underline{B} \end{aligned}$$

If we want the change in entropy at constant temperature, for example, we can apply the Helmholtz relation

$$\begin{aligned} \left( \frac{\partial S}{\partial B} \right)_T &= \left( \frac{\partial m}{\partial T} \right)_B \\ &= \frac{\partial}{\partial T} \left( \frac{V \chi_m B}{\mu_o} \right)_B \\ &= - \frac{CV}{\mu_o T^2} B \\ \rightarrow \Delta S &= - \frac{B^2 CV}{2\mu_o T^2} \end{aligned}$$

This is a negative quantity. This means that entropy decreases upon isothermal magnetisation; this is because the magnetic domains within the material become aligned, reducing the number of micro-states that the system can occupy, and so reducing disorder. We will learn more about this idea of "disorder" in Chapter (3).

The same paramagnetic material is initially at temperature  $T_1$ . Find the final temperature  $T_2$  when the field is reduced adiabatically from  $B$  to zero (adiabatic demagnetisation).

Using another cyclic relation:

$$\left(\frac{\partial T}{\partial B}\right)_S = -\left(\frac{\partial T}{\partial S}\right)_B \left(\frac{\partial S}{\partial B}\right)_T$$

Thus, we can write, using the Helmholtz function

$$\begin{aligned} \left(\frac{\partial T}{\partial B}\right)_S &= \left(-\frac{T}{c_B V}\right) \left(-\frac{CBV}{\mu_o T^2}\right) \\ &= \frac{CB}{\mu_o c_B T} \\ \frac{dT}{dB} &= \frac{TCB}{\mu_o a \left(1 + \frac{B^2 C}{\mu_o a}\right)} \end{aligned}$$

Re-arranging and integrating:

$$\begin{aligned} \int_{T_1}^{T_2} \frac{dT}{T} &= \int_B^0 \frac{CB}{\mu_o a + B^2 C} dB \\ \log\left(\frac{T_2}{T_1}\right) &= \left[\frac{1}{2} \log(\mu_o a + B^2 C)\right]_B^0 \\ &= -\frac{1}{2} \log\left(1 + \frac{B^2 C}{\mu_o a}\right) \end{aligned}$$

Thus, we arrive at the expression

$$T_2 = \frac{T_1}{\sqrt{1 + \frac{B^2 C}{\mu_o a}}}$$

## 2. *Kinetic Theory*

This chapter aims to cover the basics of Kinetic Theory, including:

- Statistical Description of a Gas
- Distributions and Isotropy
- Particle Fluxes
- Collisions
- Transport
- The Kinetic Equation

Kinetic Theory provides a much greater insight into the actual processes behind the behaviour of fluids, rather than just defining the evolution of macroscopic quantities as in Thermodynamics. It has the further advantage of always being defined, regardless of the state of the system. In this way, one could think of Thermodynamics as the study of the stable states of the system, and Kinetic Theory as the study of how it got there. Note that we will be making extensive use of probability distributions in this chapter, so it is recommended that readers are familiar with some of their basic properties and implementation.

## 2.1 Statistical Description of a Gas

In this treatment of Kinetic Theory, we will make the following assumptions about the Ideal Gas that we are considering:

- The number of particles is very large, but their separation is large in comparison to their molecular size. This means that most of the container is empty space
- The particles do not interact with one another (or the container boundaries) except via elastic, binary collisions with one another
- The particles do not experience any quantum effects; no quantum correlations
- The velocities of the particles are random and uncorrelated, according to some general distribution

In practice, all this is satisfied if the gas is sufficiently dilute (low enough number density  $n$ ) and sufficiently hot (high enough temperature  $T$ ) to avoid Quantum Mechanics, but not so hot as to run into Relativity. Evidently, we will relax some of these assumptions later, but they will hold unless otherwise stated.

Suppose that we have a container of gas at  $t = 0$ , and want to predict its behaviour at future times. One way to do this would be to know the initial position and velocity of every molecule of gas in the container, and then solve the resultant equations of motion. However, this runs into two main problems:

1. There is too much information; as there are about  $10^{23}$  molecules per  $\text{m}^3$ , we would require about  $10^{12}$  Tb of data to store this, which is more data than the entire web generated last year
2. It is very difficult, nigh impossible to determine the initial conditions. However, even if we did manage to do this, a small error would change the evolution by an order of unity in a very small time-scale, as particles experience about  $10^9$  collisions every second. Even a stray electron appearing at the edge of the observable universe would completely change the time-evolution of the system after only 150 collisions

The pertinent question is thus as to how we do indeed describe the gas.

### 2.1.1 The Thermodynamic Limit

We solve this problem by assuming that particle motion is random, meaning that  $\underline{v}$  is a random variable, and there is a sufficiently large number of particles to describe the system by average quantities. This is known as *The Thermodynamic Limit*.

Let us consider an example. Suppose that the internal energy of the gas consisting of  $N$  particles of mass  $m$  is given by the expression

$$U = \frac{1}{2}Nm \langle v^2 \rangle$$

We are just considering the energy of the motion around the mean velocity, as we can arbitrarily set this to zero. Evidently, the exact internal energy of the gas is given by the sum of the kinetic energies of the individual molecules.

$$U_e = \sum_{i=1}^N \frac{1}{2}mv_i^2$$

Is our original supposition valid? Let us calculate the variance in the energy, assuming that the velocities of the particles are independent.

$$\begin{aligned}
\sigma^2 &= \langle (U_e - U)^2 \rangle \\
&= \langle U_e^2 \rangle - U^2 \\
&= \left\langle \sum_i \frac{1}{2} m v_i^2 \sum_j \frac{1}{2} m v_j^2 \right\rangle - \left( \sum_i \frac{1}{2} m \langle v_i^2 \rangle \right)^2 \\
&= \frac{1}{4} m^2 \left[ \sum_i \langle v_i^4 \rangle + \sum_{i \neq j} \langle v_i^2 \rangle \langle v_j^2 \rangle - \left( \sum_i \langle v_i^2 \rangle \right)^2 \right] \\
&= \frac{1}{4} m^2 \left[ N \langle v^4 \rangle + N(N-1) \langle v^2 \rangle^2 - N^2 \langle v^2 \rangle^2 \right] \\
&= \frac{1}{4} N m^2 \left( \langle v^4 \rangle - \langle v^2 \rangle^2 \right)
\end{aligned}$$

Now consider the ratio of the standard deviation to the actual energy:

$$\frac{\sigma}{U_e} = \frac{1}{\sqrt{N}} \sqrt{\frac{\langle v^4 \rangle}{\langle v^2 \rangle^2} - 1} \propto \frac{1}{\sqrt{N}}$$

This means that for very large  $N$ ,  $U \approx U_e$ . This means that in The Thermodynamic Limit, average quantities are extremely good approximations, subject to the assumption that particles velocities are independent.

## 2.2 Distributions and Isotropy

As seen in the previous section, the only feasible way to describe a gas is through a statistical approach. To do this, we need to introduce the concept of a velocity distribution function  $f(\underline{v})d^3\underline{v}$ . It is the joint PDF of  $v_x$ ,  $v_y$  and  $v_z$  such that

$$\int_{-\infty}^{\infty} d^3\underline{v} f(\underline{v}) = \int_{-\infty}^{\infty} dv_x dv_y dv_z f(v_x)f(v_y)f(v_z) = 1$$

meaning that it is properly normalised throughout the entirety of phase space. It represents the fraction of molecules that have velocities in the cube  $[\underline{v}, \underline{v} + d^3\underline{v}]$  in phase space.

### 2.2.1 Isotropic Distributions

A distribution is said to be isotropic if  $f(\underline{v}) = f(v)$ ; that is, there is no special direction that influences velocity. We can thus make a transformation to polar coordinates in phase space:

$$f(\underline{v})d^3\underline{v} = f(v)v^2 \sin \theta dv d\theta d\phi$$

This means that while there is azimuthal symmetry, there is in fact a dependence on  $\theta$ . If we consider a sphere of radius  $v$  in phase-space, as in the figure below, it is evident that the volume of phase space enclosed by the ring will change depending on the value of theta, with the minimum value actually occurring for  $\theta = 0$ .

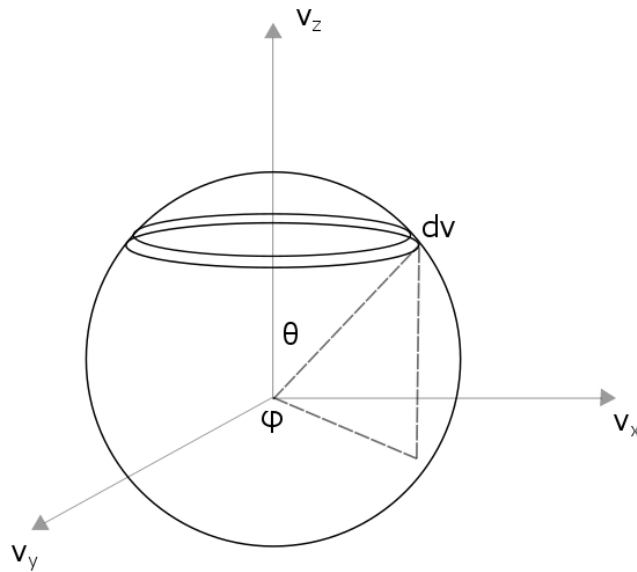

Figure 2.1: A sphere in phase space

Let the PDF of speeds be  $\tilde{f}(v)$ . Then

$$\tilde{f}(v) = \int_0^{2\pi} d\phi \int_0^\pi d\theta f(v)v^2 \sin \theta = 4\pi v^2 f(v)$$

We thus find the important relationship between the velocity and speed distributions of

$$\boxed{\tilde{f}(v) = 4\pi v^2 f(v)} \quad (2.1)$$

From this, we can already show some properties of the velocity distribution. As the system is isotropic, we can say that

$$\langle v_x^n \rangle = \langle v_y^n \rangle = \langle v_z^n \rangle = 0$$

For example, it is easy to show by direct integration that

$$\langle |v_i| \rangle = \frac{1}{2} \langle v \rangle \quad \text{and} \quad \langle v_i^2 \rangle = \frac{1}{3} \langle v^2 \rangle$$

Suppose that we have some general moment

$$\langle v_{i_1} v_{i_2} v_{i_3} \dots v_{i_n} \rangle$$

that we want to calculate for  $f(v)$ . If  $n$  is odd, then we can immediately say the expression is zero; this is because  $f(v)$  is an even function in  $v$ , and so the integral will evaluate to zero. For the other cases, we can consider some generalised, symmetric tensor to work out the desired result. For example, suppose that we want to calculate

$$\langle v_i v_j v_k v_l \rangle$$

There are six different possible tensor combinations. This means that we can write, without loss of generality, that

$$\langle v_i v_j v_k v_l \rangle = \alpha \delta_{ij} \delta_{kl} + \beta \delta_{ik} \delta_{jl} + \gamma \delta_{il} \delta_{jk}$$

As the distribution is isotropic, exchanging any two of the indices will leave the product invariant. By exchanging arbitrary combinations of the indices, it becomes clear that  $\alpha = \beta = \gamma$ . This gives

$$\langle v_i v_j v_k v_l \rangle = \alpha (\delta_{ij} \delta_{kl} + \delta_{ik} \delta_{jl} + \delta_{il} \delta_{jk})$$

Let  $i = j$  and  $l = k$ :

$$\begin{aligned} \langle v_i v_i v_k v_k \rangle &= \alpha (\delta_{ii} \delta_{kk} + \delta_{il} \delta_{li} + \delta_{il} \delta_{li}) \\ \langle v^2 v^2 \rangle &= \alpha (n^2 + n + n) \\ \langle v^4 \rangle &= \alpha (15) \\ \alpha &= \frac{1}{15} \langle v^4 \rangle \end{aligned}$$

This means that we obtain the final result of

$$\langle v_i v_j v_k v_l \rangle = \frac{1}{15} \langle v^4 \rangle (\delta_{ij} \delta_{kl} + \delta_{ik} \delta_{jl} + \delta_{il} \delta_{jk})$$

### 2.2.2 The Maxwellian Distribution

Let us assume that the distribution is proportional to the Boltzmann factor, namely that

$$f(v) \propto e^{-v^2/v_{th}^2} \quad \text{where} \quad v_{th} = \sqrt{\frac{2k_B T}{m}}$$

for the Boltzmann constant  $k_B$ . We require that the distribution function is normalised over all phase space. Hence

$$\begin{aligned} 1 &\stackrel{!}{=} \int d^3 \underline{v} f(\underline{v}) \\ \int d^3 \underline{v} f(\underline{v}) &= \left( \int_{-\infty}^{\infty} dv_i e^{-v^2/v_{th}^2} \right)^3 \\ &= (\pi v_{th}^2)^{3/2} \end{aligned}$$

We can thus write out expression for the velocity distribution as

$$f(v) = \frac{1}{(\sqrt{\pi}v_{th})^3} e^{-v^2/v_{th}^2} \quad (2.2)$$

Using (2.1), we can write the speed distribution as

$$\tilde{f}(v) = \frac{4\pi v^2}{(\sqrt{\pi}v_{th})^3} e^{-v^2/v_{th}^2} \quad (2.3)$$

This is known as the Maxwell-Boltzmann distribution. Graphically, we can represent it as

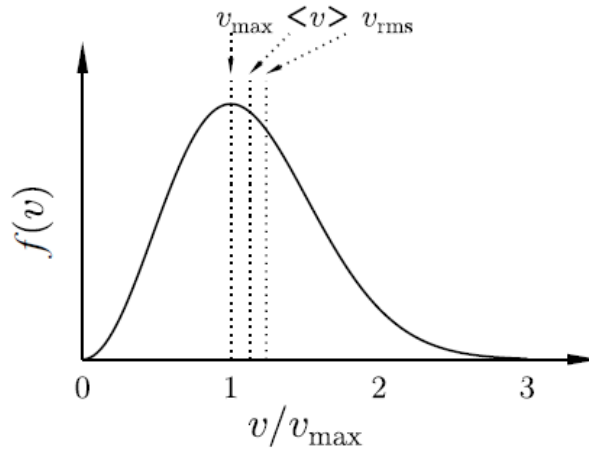

Figure 2.2: The Maxwell-Boltzmann distribution, showing  $v_{\max}$ ,  $\langle v \rangle$  and  $\sqrt{\langle v^2 \rangle}$

### Moments of the Maxwellian

Using our knowledge of probability distributions from statistics, we know that we can find the expectation value of some  $v^n$  by

$$\langle v^n \rangle = \int_0^\infty dv v^n \tilde{f}(v)$$

However, evaluating these integrals can become very long and tedious for higher powers of  $n$  as integration by parts has to be used multiple times. It can be shown, by creating a recursion formula for the integral (considering both odd and even cases) that

$$\langle v^n \rangle = \begin{cases} \frac{(n+2)!}{(\frac{n+2}{2})! 2^{n+1}} v_{th}^n & \text{for even } n \\ \frac{2}{\sqrt{\pi}} (\frac{n+1}{2})! v_{th}^n & \text{for odd } n \end{cases} \quad (2.4)$$

Evidently, these formulae do not have to be remembered, but they are just here for reference to check one's evaluation of moments. Some of the more common ones might be worth remembering.

$$\langle v \rangle = \frac{2}{\sqrt{\pi}} v_{th} \quad \langle v^2 \rangle = \frac{3}{2} v_{th}^2 \quad \langle v^3 \rangle = \frac{4}{\sqrt{\pi}} v_{th}^3$$

## 2.3 Particle Flux

Equations (2.2) and (2.3) describe the distribution of particles inside the isotropic gas, but this is not necessarily the same as, say, the distribution of particles that make contact with the walls of the container. In order to be able to find this, we need to consider the flux of particles on the walls of the container.

Let us align our  $z$ -axis perpendicular to the wall in question. Particles will only hit the wall if they are less than  $v_z$  away in some unit time. The fraction of particles with this velocity is  $f(\underline{v})d^3\underline{v}$ . This means that the number of particles in the phase-space cube  $[\underline{v}, \underline{v} + d^3\underline{v}]$  that hit the wall per-unit-area, per-unit-time is given by

$$\begin{aligned} d\Phi(\underline{v}) &= nv_z f(\underline{v})d^3\underline{v} \\ &= n(v \cos \theta) f(v) v^2 \sin \theta dv d\theta d\phi \end{aligned}$$

Our expression for particle flux thus is

$$\boxed{d\Phi(\underline{v}) = n \cos \theta \sin \theta v^3 f(v) dv d\theta d\phi} \quad (2.5)$$

- This is not a Maxwellian distribution as it has an extra factor of  $v$  in it. This means that it preferentially selects molecules with higher velocities, as these are more likely to be going quickly enough to hit the wall. The distribution of speeds is given by

$$\tilde{f}_e(v) = \frac{2v^3}{v_{th}^4} e^{-v^2/v_{th}^2} \quad (2.6)$$

This means that the most probable speed is

$$\begin{aligned} \frac{\partial}{\partial v} : \quad 0 &= 3v^2 - \frac{2}{v_{th}^2} v^4 \\ v_p &= \sqrt{\frac{3}{2}} v_{th} \end{aligned}$$

This is higher than the most probable speed for the rest of the gas  $v_{th}$ . We can conclude that, on average, particles included in this flux are moving more quickly than those that are not

- It is also not isotropic due to picking up the factor of  $\cos \theta$ . This is a manifestation of the idea of the angular size of the area element as seen from the perspective of a given particle; if it is travelling almost perpendicular to the wall, the angular size of the area element will be very small, and so is less likely to hit it. The distribution of angles is given by

$$\tilde{f}_e(\theta) = 2 \sin \theta \cos \theta \quad (2.7)$$

The most probable angle is clearly  $\pi/4$ , which is in a sense intuitively obvious

### 2.3.1 Pressure

Pressure is a form of momentum flux; it is a measure of the average amount of momentum imparted to the walls of the container by the gas. Assume that collisions of individual particles with the walls of the container are elastic, and that the wall is unaffected by the collision (massive in comparison to the particles). Particles perpendicularly incident on the wall at a speed  $v_z$  will rebound with the same speed in the opposite direction, meaning that the impulse imparted to the wall is

$$\Delta p = 2mv_z$$

where  $m$  is the mass of an individual particle. By the definition of (2.5), the number of molecules doing this per-unit-area, per-unit-time is  $d\Phi(\underline{v})$ . Hence

$$\begin{aligned}
 dp &= \Delta p d\Phi(\underline{v}) \\
 &= 2mv_z n \cos\theta \sin\theta v^3 f(v) dv d\theta d\phi \\
 &= 2mn \cos^2\theta \sin\theta v^4 f(v) dv d\theta d\phi \\
 p &= 2mn \int_0^{2\pi} d\phi \int_0^{\pi/2} d\theta \cos^2\theta \sin\theta \int_0^\infty dv v^4 f(v) \\
 &= 2mn (2\pi) \left(\frac{1}{3}\right) \int_0^\infty dv v^4 f(v) \\
 &= \frac{1}{3} mn \int_0^\infty dv v^2 \tilde{f}(v)
 \end{aligned}$$

Here we have made use of (2.1). Thus, our new expression for pressure is

$$\boxed{p = \frac{1}{3} nm \langle v^2 \rangle = \frac{2}{3} \frac{U}{V}} = nm \langle v_z^2 \rangle \quad (2.8)$$

This is in accordance with our expectations; a higher pressure may be a result of more gas molecules, or the fact that the molecules are moving more quickly.

### Recovering Thermodynamics

Using the fact that  $N = nV$ , we can write the equation for pressure as

$$\begin{aligned}
 p &= \frac{1}{2} mn v_{th}^2 \\
 &= \frac{1}{2} mn \frac{2k_B T}{m} \\
 &= nk_B T \\
 \rightarrow pV &= n_m RT
 \end{aligned}$$

where  $n_m$  is the number of moles (*not* number density) and  $R = N_A k_B$  is the universal gas constant. Note that  $N = n_m N_A$  where  $N_A$  is Avogadro's constant. We have thus obtained the Ideal Gas Law from Kinetic Theory. It is also clear from the expression for  $v_{th}$  that

$$k_B T = \frac{1}{2} m v_{th}^2$$

This means that we can now define temperature as *the energy of a particle moving at the most probable speed*, giving us a more concrete idea than we originally had when defining temperature in Section (1.2). We also see that the energy is given by

$$\boxed{U = \frac{3}{2} N k_B T = C_V T} \quad (2.9)$$

This means, as we have assumed before, that the internal energy of an ideal gas depends only on the temperature of the gas, and thus on the speed of the particles within it.

### Adiabatic Expansion

We are now equipped to consider the adiabatic expansion of a gas as in Section (1.3.2). Consider an insulated cylindrical vessel filled with monatomic ideal gas, closed on one side and plugged by a piston on the other side. The piston is very slowly pulled out at some

velocity  $u \ll v_{th}$ . Let a particle of gas, with perpendicular component of its velocity  $v_z$ , be incident on the piston.

In the rest frame of the piston, the particle is incident at velocity

$$v'_i = v_z - u$$

We assume that the velocity of the piston is unchanged as  $m_{\text{piston}} \gg m_{\text{particle}}$ . The final velocity of the particle in this frame is thus

$$v'_f = -(v_z - u)$$

Transforming back to the rest frame of the container, the final velocity of the particle is

$$\begin{aligned} v_f &= -(v_z - u) + u \\ &= -(v_z - 2u) \end{aligned}$$

The change in energy of the particle is given by

$$\begin{aligned} \Delta E &= T_{\text{initial}} - T_{\text{final}} \\ &= \frac{1}{2}m(v_z - 2u)^2 - \frac{1}{2}mv_z^2 \\ &= \frac{1}{2}m(v_z^2 - 2uv_z + 4u^2) - \frac{1}{2}mv_z^2 \\ &= -2muv_z + 2mu^2 \\ &\approx -2muv_z \end{aligned}$$

as  $u \ll v_{th}$  which is on the order of  $v_z$ . Let  $d^2\Phi_A(v_z)$  be the flux of molecules hitting the surface area element  $dA$  of the piston per unit time. This is given by

$$d^2\Phi_A(v_z) = nv_z f(v_z)dv_z dA$$

The rate of change of the internal energy of the container is thus

$$\begin{aligned} d\left(\frac{dU}{dt}\right) &= \Delta E d^2\Phi_A(v_z) \\ &= -2mnu dA v_z^2 f(v_z)dv_z \\ \frac{dU}{dt} &= -2mnu dA \int_0^\infty dv_z v_z^2 f(v_z) \\ &= -mnu dA \langle v_z^2 \rangle \\ &= -\frac{1}{3}mnu dA \langle v^2 \rangle \end{aligned}$$

by symmetry. This can be written as

$$\frac{dU}{dt} = -\frac{2}{3} \frac{U}{V} u dA$$

However,  $u dA$  is simply the rate at which the volume increases.

$$\frac{dU}{dt} = -\frac{2}{3} \frac{U}{V} \frac{dV}{dt}$$

This differential equation can easily be solved, and using the ideal gas law allows us to re-obtain the result we derived in Thermodynamics of

$$pV^{5/3} = \text{constant}$$

This time, we have a better understanding of where this result comes from; it is the change in the internal energy of the gas particles that occurs as the volume expands as a result of work being done on the piston.

### 2.3.2 Effusion

Suppose now that we open a small hole of dimension  $d \ll \lambda_{mfp}$  (the typical distance travelled by a given particle, as we will see later) in the side of the container. Then, flux of particles escaping through the hole or *effusing* is simply given by

$$\begin{aligned}\Phi(\underline{v}) &= \int d\Phi(\underline{v}) \\ &= n \int_0^{2\pi} d\phi \int_0^{\pi/2} d\theta \sin\theta \cos\theta \int_0^\infty dv v^3 f(\underline{v}) \\ &= \frac{1}{4} n \langle v \rangle\end{aligned}$$

Using the fact that  $p = nk_B T$  and assuming that the distribution is Maxwellian, we can arrive at the expression

$$\boxed{\Phi = \frac{p}{\sqrt{2\pi m k_B T}}} \quad (2.10)$$

Once again, the distribution of effusing particles has the properties outlined in Section (2.3); faster particles, and those that make small angles with the normal, are more likely to effuse. We have derived this expression assuming that *all* incident angles are possible. Suppose instead that we wanted to find the flux of particles that effuse into a particular solid angle. Then, instead of integrating  $\theta$  over the interval  $[0, \pi/2]$ , we would integrate up to the corresponding solid angle.

Effusion can be used experimentally as a way of measuring internal properties of the distribution without modifying the distribution itself. For example, we can find the vapour pressure of a gas inside a container by measuring the rate of change of mass inside that container. Suppose that the particles effuse through a hole of area  $A$ . Then the rate of change of mass is

$$\begin{aligned}\frac{dM}{dt} &= m \Phi A \\ &= p A \sqrt{\frac{m}{2k_B \pi T}} \\ p &= \sqrt{\frac{2k_B \pi T}{m}} \frac{1}{A} \frac{dM}{dt}\end{aligned}$$

*A closed vessel is partially filled with liquid mercury; there is a hole of area  $A = 10^7 \text{ m}^2$  above the liquid level. The vessel is placed in a region of high vacuum at  $T = 273 \text{ K}$  and after 30 days is found to be lighter by  $\Delta M = 2.4 \times 10^5 \text{ kg}$ . Estimate the vapour pressure of mercury at 273 K. (The relative molecular mass of mercury is 200.59)*

We have already derived the appropriate expression, it is just a matter of putting the information together.

$$\begin{aligned}\frac{\Delta M}{\Delta t} &\approx 9.26 \times 10^{-12} \text{ kgs}^{-1} \\ m &= \frac{\text{Relative Atomic Mass}}{N_a} \\ &\approx 3.3 \times 10^{-25} \text{ kg} \\ \rightarrow p &\approx 0.0247 \text{ Nm}^{-2}\end{aligned}$$

This is the approximate vapour pressure of mercury, assuming that the system is at equilibrium.

### Conditions for Equilibrium

Suppose that we have two containers joined by a hole of radius  $a$ . What are the conditions for now flow between the containers? This will actually depend on the size of the hole.

- $a \gg \lambda_{mfp}$  - In this case, we require that the pressures balance, namely

$$\boxed{n_1 T_1 = n_2 T_2} \quad (2.11)$$

- $a \ll \lambda_{mfp}$  - This is the effusive case. Evidently, we require that the effusive flux is the same in both directions, namely

$$\boxed{n_1 \sqrt{T_1} = n_2 \sqrt{T_2}} \quad (2.12)$$

Remember that in both cases, total number density  $n = n_1 + n_2$  must be conserved.

### Some results of Effusion

Suppose that we have a container with a small hole of area  $A$ . We can use the expression for particle flux, under the effusion condition, to find the rate of change of some quantities inside the container.

- Number Density - The rate of particles escaping from the container is evidently

$$\frac{dN}{dt} = -\Phi A = -\frac{1}{4} A \langle v \rangle n$$

Dividing through by the volume in the container, we find that the differential equation for the number density is given by

$$\boxed{\frac{dn}{dt} = -\frac{1}{4} \frac{A}{V} \langle v \rangle n} \quad (2.13)$$

If the temperature of the vessel remains constant, this can simply be solved to find  $n(t)$  and consequently  $p(t)$ .

- Energy - We need to calculate the energy flux  $J$

$$\begin{aligned} dJ &= d\Phi(v) \cdot \frac{1}{2} m v^2 \\ J &= \frac{1}{8} n m \langle v^3 \rangle \end{aligned}$$

This means that we can write the rate of change of the internal energy as

$$\boxed{\frac{dU}{dt} = -J A} \quad (2.14)$$

Recalling (2.9), we find that  $U = U(n, T)$ . Assuming that neither  $n$  or  $T$  remain constant (such as for an isolated container), we can obtain a set of coupled equations for these variables from the above equation, which we can then solve for their time evolution.

## 2.4 Collisions

Let us only consider binary collisions between two sets of particles, where the particles can be modelled as hard spheres. Let the two species have radii  $r_1$  and  $r_2$  respectively, and the same number density  $n$ . Imagine now that only one particle is moving, with all others fixed. The particles that it will collide with are contained within the cylinder of volume  $\pi(r_1 + r_2)^2 vt$  for some characteristic speed of the system  $v$ . We define

$$\boxed{\sigma = \pi(r_1 + r_2)^2} \quad (2.15)$$

This is known as the collision cross section. The number of particles in this imaginary cylinder is then given by  $\sigma nvt$ . The collision time  $t = \tau_c$  occurs when the number of particles in this cylinder is one.

$$\begin{aligned} \sigma n v \tau_c &= 1 \\ \tau_c &= \frac{1}{\sigma n v} \end{aligned}$$

Then, the typical distance between collisions is given by

$$\boxed{\lambda_{mfp} = \frac{1}{\sigma n}} \quad (2.16)$$

This is known as the *mean free path* of the particles. Both  $\lambda_{mfp}$  and  $\tau_c$  both obey the exponential probability distribution; this makes sense, as the probability that particles have not collided after long times or distances will be very low as quantities are very small. Typically,  $\tau_c \sim 10^{-9}$ ,  $\lambda_{mfp} \sim 10^{-6}$  and  $r \sim 10^{-10}$ .

### 2.4.1 The Characteristic Velocity

We have not addressed the question of what this characteristic velocity  $v$  should be. As we have assumed that all particles (apart from the one that we were considering) were stationary, it makes the most sense for  $v$  to be the relative velocity between the particles. For a large number of particles, we know that  $\langle v \rangle \approx \langle v^2 \rangle^{1/2}$ . Then:

$$\begin{aligned} \langle v_r^2 \rangle &= \langle |\underline{v}_1 - \underline{v}_2|^2 \rangle \\ &= \langle v_1^2 \rangle + \langle v_2^2 \rangle - 2 \langle \underline{v}_1 \cdot \underline{v}_2 \rangle \\ &= 2 \langle v^2 \rangle \\ v &\approx \sqrt{2} \langle v \rangle \end{aligned}$$

We have made the important assumption that the velocities of the particles prior to the collision are independent; that is, the particles have collided enough times with other particles prior to a second collision that we can neglect any effect of the previous collision. This assumption breaks down at low  $n$ .

It turns out that we do not need to be this specific when specifying this characteristic velocity  $v$ . On these scales,

$$v_{th} \sim \langle v \rangle \sim \langle v^2 \rangle^{1/2}$$

This means that our choice of  $v$  in fact makes very little difference; which one we use is essentially the definition of  $\tau_c$  in that case.

### 2.4.2 Collisions in a Mixture

Consider a more general case where we have two species of particle in the same container, one with effective collision radius  $r_1$  and number density  $n_1$ , and the other with  $r_2$  and  $n_2$ . What is the time between collisions for collisions of type-1 particles with type-2 particles? Using the same argument as before,

$$\tau_c = \frac{1}{\sigma_{12}n_1v}$$

However, in this case,  $v$  is not as easily well defined. Once again, we will assume that the particle velocities are independent, namely that

$$f(\underline{v}_1, \underline{v}_2) = f(\underline{v}_1)f(\underline{v}_2)$$

Assume that both species have a Maxwellian distribution. Then

$$\begin{aligned} \langle v_r \rangle &= \int \int d^3\underline{v}_1 d^3\underline{v}_2 |v_1 - v_2| f(\underline{v}_1, \underline{v}_2) \\ &= \int \int d^3\underline{v}_1 d^3\underline{v}_2 |v_1 - v_2| \left( \frac{1}{(\sqrt{\pi}u_1)^3} e^{-v_1^2/u_1^2} \right) \left( \frac{1}{(\sqrt{\pi}u_2)^3} e^{-v_2^2/u_2^2} \right) \end{aligned}$$

We now want to make the substitutions that  $v_r = v_1 - v_2$  and  $V = \frac{m_1v_1 + m_2v_2}{m_1 + m_2}$  such that  $d^3\underline{v}_1 d^3\underline{v}_2 = d^3V d^3\underline{v}_r$ . Then

$$\begin{aligned} \frac{v_1^2}{u_1^2} + \frac{v_2^2}{u_2^2} &= \frac{1}{2k_B T} \left[ V^2 (m_1 + m_2) + v_r^2 \left( \frac{m_1 m_2^2 + m_1^2 m_2}{(m_1 + m_2)^2} \right) \right] \\ &= \frac{1}{2k_B T} \left[ V^2 (m_1 + m_2) + v_r^2 \left( \frac{m_1 m_2}{m_1 + m_2} \right) \right] \\ &= \frac{1}{2k_B T} [V^2(M_t) + v_r^2(\mu)] \\ &= \frac{V^2}{(2k_B T)/M_t} + \frac{v_r^2}{(2k_B T)/\mu} \\ &= \frac{V^2}{u_t^2} + \frac{v_r^2}{u_\mu^2} \end{aligned}$$

Thus, the final expression that we want to evaluate is

$$\begin{aligned} \langle v_r \rangle &= \frac{1}{(\pi u_t u_\mu)^3} \int \int d^3V d^3\underline{v}_r v_r e^{-\left(\frac{V^2}{u_t^2} + \frac{v_r^2}{u_\mu^2}\right)} \\ &= \int d^3V \frac{1}{(\sqrt{\pi}u_t)^3} e^{-V^2/u_t^2} \int d^3\underline{v}_r \frac{v_r}{(\sqrt{\pi}u_\mu)^3} e^{-v_r^2/u_\mu^2} \\ &= \left( \int d^3V_x \frac{1}{(\sqrt{\pi}u_t)^3} e^{-V_x^2/u_t^2} \right)^3 \int d^3\underline{v}_r \frac{v_r}{(\sqrt{\pi}u_\mu)^3} e^{-v_r^2/u_\mu^2} \\ &= \int d^3\underline{v}_r \frac{v_r}{(\sqrt{\pi}u_\mu)^3} e^{-v_r^2/u_\mu^2} \\ &= \frac{2}{\sqrt{\pi}} u_\mu \end{aligned}$$

This means that we obtain a final expression for the collision frequency  $\nu_c = 1/\tau_c$  as

$$\boxed{\nu_c = (r_1^2 + r_2^2) \sqrt{\frac{8\pi k_B T}{\mu}}} \quad (2.17)$$

## 2.5 Transport

This section focusses on examining how a gas transports quantities, which could be momentum, energy or other particles themselves, from one place to another. We will still be considering the system to be globally in the steady state, but changing locally. In all derivations, we assume that the pressure is not too high ( $\lambda \gg d$ , where  $d$  is the molecular diameter) such that we can neglect collisions involving more than two particles, and the pressure is not too low ( $\lambda \ll L$ , where  $L$  is the length scale of the container) such that the particles mainly collide with one another and not the walls of the container.

### 2.5.1 Thermal Conductivity

Let  $\underline{J}$  be the heat flux in the gas that results from some temperature gradient  $\nabla T$ , such that  $\underline{J} = 0$  when  $\nabla T = 0$ . By the conservation of energy, we know that  $\underline{J}$  has to have the opposite sign to  $\nabla T$ . Assuming that the temperature gradient is small, we can write that

$$\begin{aligned}\underline{J} &= \underline{J}(\nabla T) \\ &\approx \underline{J}(0) + \underline{J}'(0) \nabla T + \dots \\ &= -\kappa \nabla T + \dots\end{aligned}$$

This means that to first order

$$\boxed{\underline{J} = -\kappa \nabla T} \quad (2.18)$$

where  $\kappa$  is known as the *coefficient of thermal conductivity*.

Consider a particle travelling with some component of velocity in the positive  $z$  direction that crosses a plane of constant  $z$ . As the particles travel an average of  $\lambda_{mfp} \equiv \lambda$  between collisions, the distance travelled parallel to the  $z$ -axis is  $\delta z = \lambda \cos \theta$  (see Figure (2.3)). These particles arriving at  $z$  from  $z - \delta z$  will bring some extra energy  $\delta E$ . Let the heat capacity per particle be  $c_n = 3k_B/2$ . Then

$$\begin{aligned}\delta E &= c_n T(z - \delta z) - c_n T(z) \\ &= c_n \left( T(z) - \frac{\partial T}{\partial z} \delta z \right) - c_n T(z) \\ &= -c_n \frac{\partial T}{\partial z} \lambda \cos \theta\end{aligned}$$

The total energy flux in the  $z$ -direction is

$$\begin{aligned}J_z &= \int d\Phi(\underline{v}) \delta E \\ &= -c_n \lambda \frac{\partial T}{\partial z} \int d\Phi(\underline{v}) \cos \theta \\ &= -\frac{1}{3} n c_n \langle v \rangle \lambda \frac{\partial T}{\partial z}\end{aligned}$$

Comparing this with the  $z$  component of (2.18), we find that

$$\boxed{\kappa = \frac{1}{3} c_v \lambda \langle v \rangle} \quad (2.19)$$

where  $c_v = 3/2 n k_B = \rho c_m$  is the heat capacity per unit volume. Interestingly, we see that  $\kappa$  is independent of  $n$  and thus pressure as  $\lambda \propto 1/n\sigma$ .

The thermal conductivity of argon (atomic weight 40) at S.T.P. is  $1.6 \times 10^2 \text{ Wm}^{-1} \text{ K}^{-1}$ . Find the effective collision radius. Solid argon has a close packed cubic structure, in which, if the atoms are regarded as hard spheres, 0.74 of the volume of the structure is filled. The density of solid argon is  $1.6 \text{ gcm}^3$ . Find the effective radius in this case, and compare the two results

Using the fact that  $C_V = 3/2Nk_B$ , we can rearrange (2.19) to find that

$$\lambda = \frac{\kappa}{k_B N \sqrt{\frac{2k_B T}{\pi m}}} \approx 1 \times 10^{-7} \text{ m}$$

From the definition of  $\lambda$ ,

$$\begin{aligned} \lambda &= \frac{1}{n\sigma} \\ &= \frac{1}{4\pi r_1^2 n} \\ r_1 &= \frac{1}{\sqrt{4\pi n\lambda}} \approx 1.93 \times 10^{-10} \text{ m} \end{aligned}$$

Now for solid argon,

$$\begin{aligned} NV_{\text{atom}} &= 0.74V_{\text{total}} \\ n \left( \frac{4}{3}\pi r_2^3 \right) &= 0.74 \\ \frac{4}{3}\pi r_2^3 &= 0.74 \frac{m}{\rho} \\ r_2 &\approx 1.95 \times 10^{-10} \text{ m} \end{aligned}$$

These answers are different because the hard sphere approximation used to derive  $\lambda$  becomes less accurate. This is because at higher temperatures, the particles are more energetic, meaning that more of a 'direct hit' is required to cause a collision, leading to a reduction in effective collision radius.

## 2.5.2 Viscosity

Let us consider a one-dimensional shear flow

$$\underline{u} = u_x(t, z) \hat{x}$$

That is, a flow in the  $x$  direction whose magnitude depends on the value of  $z$ . Suppose that at lower values of  $z$ ,  $u_{zx}$  is greater than at higher values. Then particles that travel to  $z$  from  $z - \delta z$  will bring some extra momentum with them, as in Figure (2.3), creating a momentum flux  $\Pi_{zx}$  against the velocity gradient  $\nabla u_x$ .

We know that  $\Pi_{zx} = 0$  for  $\nabla u_x = 0$ , and (by the conservation of energy) that  $\Pi_{zx}$  must have the opposite sign to  $\nabla u_x$ . Assuming that the shear velocity gradient is small, we can write that

$$\begin{aligned} \Pi_{zx} &= \Pi_{zx} \left( \frac{\partial u_x}{\partial z} \right) \\ &\approx \Pi_{zx}(0) + \Pi'_{zx}(0) \frac{\partial u_x}{\partial z} + \dots \\ &= -\eta \frac{\partial u_x}{\partial z} + \dots \end{aligned}$$

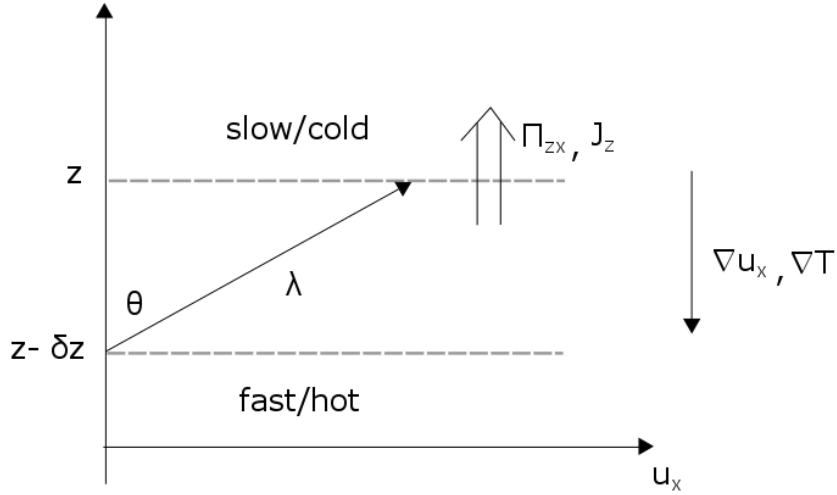

Figure 2.3: Transport due to a temperature and velocity gradient

This means that to first order

$$\boxed{\Pi_{zx} = -\eta \frac{\partial u_x}{\partial z}} \quad (2.20)$$

where  $\eta$  is known as the *coefficient of dynamical viscosity*.

Let us calculate the extra momentum brought by each particle.

$$\begin{aligned} \delta p &= m u_x(z - \delta z) - m u_x(z) \\ &\approx m \left( u_x(z) - \frac{\partial u_x}{\partial z} \delta z \right) - m u_x(z) \\ &= -m \frac{\partial u_x}{\partial z} \lambda \cos \theta \end{aligned}$$

This means that the total momentum flux is given by

$$\begin{aligned} \Pi_{zx} &= \int d\Phi(v) \delta p \\ &= -nm \frac{\partial u_x}{\partial z} \lambda \int d\Phi(v) \cos \theta \\ &= -\frac{1}{3} nm \lambda \langle v \rangle \frac{\partial u_x}{\partial z} \end{aligned}$$

Comparison with (2.20) yields

$$\boxed{\eta = \frac{1}{3} nm \lambda \langle v \rangle} \quad (2.21)$$

Interestingly, we also find that this is independent of pressure. How can this be? At lower pressures, less particles will be moving through this plane of constant  $z$ , but they will have a longer  $\lambda$ . This means that each particle is individually better at transmitting momentum, and so this cancels out the effect of having fewer particles producing the momentum flux. Evidently, this will start to break down when  $\lambda$  is on the order of magnitude of the size of the container.

A momentum flux is simply analogous to a pressure; in this case, it is the pressure that each infinitesimal layer of gas exerts on adjacent layers. For finite differences in velocity and separation, we can write that

$$\boxed{\frac{F}{A} = -\eta \frac{\Delta u}{\Delta z}} \quad (2.22)$$

where  $\Delta u$  is the velocity difference *perpendicular* to the separation  $\Delta z$ .

*Two plane disks, each of radius 5 cm, are mounted coaxially with their adjacent surfaces 1 mm apart. They are in a chamber containing Ar gas at S.T.P. (viscosity  $2.1 \times 10^{-5}$  Nsm<sup>2</sup>) and are free to rotate about their common axis. One of them rotates with an angular velocity of 10 rad s<sup>-1</sup>. Find the couple which must be applied to the other to keep it stationary.*

We want to consider the force exerted on the disk in the  $\hat{\theta}$  direction along the edge of the disk.

$$F_{\theta} = -\eta \frac{\partial u_{\theta}}{\partial z} A$$

Converting to torque, we multiply by  $r$  as  $r \perp F$ . As  $u_{\theta}$  is the velocity at  $r$ ,  $u_{\theta} = \omega r$ .

$$\begin{aligned} d\tau_{\theta} &= -\eta r \frac{\partial u_{\theta}}{\partial z} dA \\ &= -\eta r \frac{\partial(\omega r)}{\partial z} (2\pi r) dr \\ &= -\eta \frac{\partial \omega}{\partial z} 2\pi r^3 dr \\ &\approx -\eta \frac{\omega}{z} 2\pi r^3 dr \end{aligned}$$

for a small gap  $z$ . Integrating:

$$\tau = -\eta \frac{\omega}{z} \frac{\pi a^4}{4}$$

We thus find that  $\tau \approx 2 \times 10^{-6}$ . For a disk that is slowing down, we can find the rate of change of  $\omega$  by recalling that  $\tau = I d\omega/dt$ , where  $I = 1/2 m a^2$  for a disk.

### 2.5.3 Self-Diffusion

A gas can move itself around, in a sense. If we have some labelled particles of number density  $n^*(\underline{r})$ , then this distribution will change over time as the particles within the overall gas. As these particles move, they set up a 'number gradient'  $\nabla n^*$ . What is the flux of the labelled particles  $\Phi^*$ ? By the same logic as before, we know that  $\Phi^* = 0$  if  $\nabla n^* = 0$ , and (by number density conservation) that it must be opposite in sign. We can thus write

$$\begin{aligned} \underline{\Phi}^* &= \Phi^*(\nabla n^*) \\ &\approx \Phi^*(0) + \Phi^{*'}(0) \nabla n^* + \dots \\ &= -D^* \nabla n^* + \dots \end{aligned}$$

This means that to first order

$$\boxed{\underline{\Phi}^* = -D^* \nabla n^*} \quad (2.23)$$

where  $D^*$  is the *coefficient of self-diffusion*.

Now, consider a particle travelling with some component of velocity in the positive  $z$  direction that crosses a plane of constant  $z$ . Using the same argument as before, the number of extra particles  $\delta n^*$  that arrive is

$$\begin{aligned}\delta n^* &= n^*(z - \delta z) - n^*(z) \\ &= n^*(z) - \frac{\partial n^*}{\partial z} \delta z - n^*(z) \\ &= -\frac{\partial n^*}{\partial z} \lambda \cos \theta\end{aligned}$$

Then the total flux of the labelled particles in the  $z$  direction is

$$\begin{aligned}\Phi_z^* &= \int d\Phi(\underline{v}) \delta n^* \\ &= -\frac{\partial n^*}{\partial z} \lambda \int d\Phi(\underline{v}) \cos \theta \\ &= -\frac{1}{3} \lambda \langle v \rangle \frac{\partial n^*}{\partial z}\end{aligned}$$

Comparison with (2.23) yields

$$\boxed{D^* = \frac{1}{3} \lambda \langle v \rangle} \quad (2.24)$$

It is clear that  $D^* \propto p^{-1}$ ; for higher pressures, we would expect molecules to be able to travel a shorter distance due to a greater number of collisions, and hence a lower coefficient of self-diffusion. Observing that  $\rho = nm$ , we obtain the useful relationship that  $D^* \rho = \eta$ .

Consider a volume  $V$  of gas bounded by a closed surface  $S$ . Then the rate of change of the number density  $n^*$  within the volume will be opposite and equal to the number of the labelled particles that leave the volume via this surface.

$$\begin{aligned}\frac{\partial}{\partial t} \int_V d^3\underline{r} n^* &= - \int_{\partial V} d\underline{S} \cdot \underline{\Phi}^* \\ &= - \int_V d^3\underline{r} \nabla \cdot \underline{\Phi}^* \\ &= \int_V d^3\underline{r} D^* \nabla^2 n^*\end{aligned}$$

by the Divergence Theorem and (2.24). As we are integrating over an arbitrary volume, we can write

$$\boxed{\frac{\partial n^*}{\partial t} = D^* \nabla^2 n^*} \quad (2.25)$$

This is known as the *self-diffusion equation*.

## 2.5.4 Heat Diffusion

We have already found the coefficient for thermal conductivity. We now want to find how temperature flows within the gas, which is directly related to the rate at which energy is transported throughout the gas. In a similar vein to the previous section, consider a volume  $V$  of gas bounded by a closed surface  $S$ . Then the rate at which energy changes in the volume is going to be opposite and equal to the amount of energy that leaves the volume through this surface. The energy density  $\varepsilon$  of the gas is given by

$$\varepsilon = \frac{U}{V} = \frac{3}{2} n k_B T = c_v T$$

Then we can write

$$\begin{aligned}\frac{\partial}{\partial t} \int_V d^3r \varepsilon &= - \int_{\partial V} d\underline{S} \cdot \underline{J} \\ &= - \int_V d^3r \nabla \cdot \underline{J}\end{aligned}$$

by the Divergence Theorem. As we are integrating over an arbitrary volume, we can write

$$\frac{\partial \varepsilon}{\partial t} + \nabla \cdot \underline{J} = 0$$

This is the energy conservation equation for the gas. Suppose that there is a source of heat that generates heat at a rate  $H$  per unit volume. Assume that there is no loss of the gas particles, meaning that  $n$  is time-independent. Using (2.18):

$$\begin{aligned}\frac{\partial(c_v T)}{\partial t} + \nabla \cdot (-\kappa \nabla T) &= H \\ c_v \frac{\partial T}{\partial t} &= \kappa \nabla^2 T + H\end{aligned}$$

Re-arranging, we arrive at the *heat diffusion equation*

$$\boxed{\frac{\partial T}{\partial t} = \alpha \nabla^2 T + \frac{H}{c_v}} \quad (2.26)$$

Here,  $\alpha = \kappa/c_v$  is known as the *coefficient of thermal diffusivity*.

### Newton's Law of Cooling

Newton's law of cooling states that the temperature of a cooling body falls exponentially towards the temperature of its surroundings with a rate which is proportional to the area of contact between the body and the environment. Evidently, this is not always true, as objects tend to cool exponentially only at long times as the leading exponential term becomes dominant. Mathematically, we can express this as

$$\boxed{\underline{J} = h \underline{\Delta} T} \quad (2.27)$$

where  $\Delta T = T - T_{\text{surroundings}}$ , and  $\underline{h}$  is a vector perpendicular to the surface whose magnitude is the heat transfer coefficient.

### Some Examples

Let us take a look at some examples of problems concerning the heat equation.

1. A cylindrical wire of thermal conductivity  $\kappa$ , radius  $a$  and resistivity  $\rho$  uniformly carries a current  $I$ . The wire is now placed in air at temperature  $T_o$  and the wire loses heat from its surface according to Newton's law of cooling. Find the temperature  $T(r)$ .

We shall assume that the wire is sufficiently long that there is no  $z$  dependence. We know that in the steady state, the heat loss to the surroundings must be opposite and equal to the heat generated. Let the heat transfer coefficient be  $h$ .

$$\begin{aligned}JA &= VH \\ 2\pi a \ell (h(T(a) - T_o)) &= \pi a^2 \ell H \\ h(T(a) - T_o) &= \frac{a}{2} H \\ T(a) &= T_o + \frac{a}{2h} H\end{aligned}$$

This is our boundary condition at the surface. Assuming that the wire obey's Ohmic heating:

$$\begin{aligned} H &= \frac{I^2 R}{\pi a^2 \ell} \\ &= \frac{I^2}{\pi a^2 \ell} \left( \frac{\rho \ell}{A} \right) \\ &= \frac{\rho I^2}{\pi^2 a^4} \end{aligned}$$

We shall then assume that the system is in the steady state. This means that the heat equation becomes

$$\begin{aligned} \nabla^2 T &= -\frac{H}{\kappa} \\ \frac{1}{r} \frac{d}{dr} \left( r \frac{dT}{dr} \right) &= -\frac{H}{\kappa} \\ r \frac{dT}{dr} &= -\frac{Hr^2}{2\kappa} + c_1 \\ T(r) &= -\frac{Hr^2}{4\kappa} + c_1 \log(r) + c_2 \end{aligned}$$

We require the solution to be finite at  $r = 0$ , meaning that  $c_1 = 0$ . Imposing the condition derived above:

$$\begin{aligned} T(a) &= -\frac{Ha^2}{4\kappa} + c_2 \\ T_o + \frac{a}{2h} H &= -\frac{Ha^2}{4\kappa} + c_2 \\ c_2 &= T_o + \frac{a}{2h} H + \frac{Ha^2}{2\kappa} \end{aligned}$$

This means that the final solution is

$$T(r) = T_o + \frac{\rho I^2}{4\pi^2 a^4 \kappa} (a^2 - r^2) + \frac{\rho I^2}{8\pi^2 a^3 h}$$

2. Consider a thick, uniform layer of material with coefficient of thermal diffusivity  $\alpha$ . Solve for the time evolution of the system given the following boundary conditions:

- The surface of the layer is subject to a time-dependant sinusoidal temperature variation given by

$$T(0, t) = T_o + \sum_n T_n \cos(nt)$$

Suppose that the solution is of the form

$$T(x, t) = \sum_{\omega} \tilde{T}(x, \omega) e^{i\omega t}$$

Take the FT of both sides of the heat equation:

$$\begin{aligned} \int_{-\infty}^{\infty} dt e^{-i\omega t} \frac{\partial T}{\partial t} &= \alpha \int_{-\infty}^{\infty} dt e^{-i\omega t} \frac{\partial^2 T}{\partial x^2} \\ i\omega \tilde{T} &= \alpha \frac{\partial^2 \tilde{T}}{\partial x^2} \\ \tilde{T}(x, 0) &= c_1 e^{ikx} + c_2 e^{-ikx} \end{aligned}$$

We require that  $c_2 = 0$  for the solution to be properly bounded. Let  $c_1 = \tilde{T}(0, \omega)$ .

$$\begin{aligned} i\omega &= -\alpha k^2 \\ k^2 &= -\frac{i\omega}{\alpha} \\ k &= (-1 + i)\sqrt{\frac{\omega}{2\alpha}} = \frac{1}{\delta_\omega}(-1 + i) \end{aligned}$$

Thus, the final solution is of the form

$$\boxed{T(x, t) = \sum_w \tilde{T}(0, \omega) e^{-x/\delta_\omega} e^{i(\omega t - x/\delta_\omega)}} \quad (2.28)$$

$\delta_\omega$  is known as the *skin depth*, and is a measure of the attenuation of the propagating wave. Calculating the FT of the initial condition:

$$\begin{aligned} \tilde{T}(0, \omega) &= T_o + \int_{-\infty}^{\infty} dt e^{-i\omega t} \sum_n T_n \cos(nt) \\ &= T_o + \frac{1}{2} \sum_n T_n \int_{-\infty}^{\infty} dt e^{-i\omega t} (e^{int} + e^{-int}) \\ &= T_o + \frac{1}{2} \sum_n T_n \int_{-\infty}^{\infty} dt e^{-i(\omega - n)t} + e^{-i(\omega + n)t} \\ &= T_o + \frac{1}{2} \sum_n T_n \cdot (\delta(\omega - n) + \delta(\omega + n)) \end{aligned}$$

Substituting this result back into (2.28), we find that

$$T(x, t) = T_o + \sum_n T_n e^{-x/\delta_n} \cos\left(nt - \frac{x}{\delta_n}\right)$$

- *The interior of the material is subject to a space-dependant sinusoidal temperature variation given by*

$$T(x, 0) = T_o + \sum_n T_n \cos(nx)$$

Suppose that the solution is of the form

$$T(x, t) = \sum_k \tilde{T}(k, t) e^{ikx}$$

Taking the FT of both sides of the heat equation:

$$\begin{aligned} \int_{-\infty}^{\infty} dk e^{-ikx} \frac{\partial T}{\partial t} &= \int_{-\infty}^{\infty} dk e^{-ikx} \frac{\partial^2 T}{\partial x^2} \\ \frac{\partial}{\partial t} \int_{-\infty}^{\infty} dk e^{-ikx} T &= \alpha (ik)^2 \tilde{T} \\ \frac{\partial \tilde{T}}{\partial t} &= -\alpha k^2 \tilde{T} \\ \tilde{T}(k, t) &= \tilde{T}(k, 0) e^{-\alpha k^2 t} \end{aligned}$$

Thus, the final solution is of the form

$$T(x, t) = \sum_k \tilde{T}(x, 0) e^{-\alpha k^2 t} e^{ikx} \quad (2.29)$$

Calculating the FT of the initial condition as above, we arrive at the final solution of

$$T(x, t) = T_o + \sum_n T_n \cos(nx)$$

Note that in this section, we have used a different normalisation convention on the Fourier Transform than in the Mathematical Methods notes.

## 2.6 Local Equilibrium

Note that the material covered in this section is not on syllabus, but we have included it here for the sake of interest.

Up until this point, we have assumed that the distribution function of the particles depended only on their velocity  $\underline{v}$ . However, this may not always be the case, as there might be some region of the gas with a higher number density or with some mean flow  $\underline{u}$ . With this in mind, allow the distribution to depend on both position ( $\underline{r}$ ) and time ( $t$ ):  $F(t, \underline{r}, \underline{v})$ . The expression  $F(t, \underline{r}, \underline{v}) d^3\underline{r} d^3\underline{v}$  thus represents the fraction of particles with velocities in the range  $[\underline{v}, \underline{v} + d^3\underline{v}]$  and located in the cube in space  $[\underline{r}, \underline{r} + d^3\underline{r}]$  at a given time  $t$ .

Let our macroscopic scales of the system be  $\ell$  and  $t$ . These are the scales on which the gas is inhomogeneous; that is, the scales on which any variations are measurable. Suppose that we now break the system into small fluid 'elements' of size  $\delta\ell$  and observe them for a time  $\delta t$ . Then we still have

$$\begin{aligned}\ell &\gg \delta\ell \gg \lambda_{mfp} \\ t &\gg \delta t \gg \tau_c\end{aligned}$$

On these scales, these fluid elements can be considered to be *almost* homogeneous, and hence can be considered to be Maxwellian in this locality. This means that we arrive at the local distribution function

$$F_M(t, \underline{r}, \underline{v}) = \frac{n(t, \underline{r})}{(\sqrt{\pi}v_{th})^3} e^{-|\underline{v}-\underline{u}|^2/v_{th}^2} \quad (2.30)$$

for some mean flow  $\underline{u} = \underline{u}(t, \underline{r})$ , and  $v_{th}$  that depends on some temperature distribution  $T(t, \underline{r})$ . Evidently, global equilibrium occurs where  $n$ ,  $\underline{u}$  and  $T$  are constant. However, for any evolution to occur, this has to not be the case. This means that in fact these local distributions are not quite Maxwellian. We thus write

$$F(t, \underline{r}, \underline{v}) = \underbrace{F_M(t, \underline{r}, \underline{v})}_{\text{local Maxwellian}} + \underbrace{\delta F(t, \underline{r}, \underline{v})}_{\text{local relaxation}}$$

### 2.6.1 The Kinetic Equation

Consider the particles present at  $\underline{r}$  with velocities  $\underline{v}$  at a time  $t + \delta t$ . Particles with these properties will either be those that move into this location, or those that are scattered into this velocity.

$$F(t + \delta t, \underline{r}, \underline{v}) = \underbrace{F(t, \underline{r} - \underline{v}\delta t, \underline{v})}_{\text{ballistic motion}} + \underbrace{\delta F_c}_{\text{contribution from collisions}}$$

Assuming that  $\delta t \ll 1$ , we can Taylor expand as

$$F(t + \delta t, \underline{r}, \underline{v}) \approx F(t, \underline{r}, \underline{v}) - (\underline{v}\delta t) \cdot \nabla F(t, \underline{r}, \underline{v})$$

Dividing through by  $\delta t$  and taking the limit

$$\lim_{\delta t \rightarrow 0} \frac{F(t + \delta t, \underline{r}, \underline{v}) - F(t, \underline{r}, \underline{v})}{\delta t} = \lim_{\delta t \rightarrow 0} -\underline{v} \cdot \nabla F(t, \underline{r}, \underline{v}) + \frac{\delta F_c}{\delta t}$$

This means that we obtain the *Kinetic Equation*

$$\boxed{\frac{\partial F}{\partial t} + \underline{v} \cdot \nabla F = C[F]} \quad (2.31)$$

where  $\underline{v}$  is the velocity of the particles, and  $C[F]$  is known as the *collision operator*. We know that  $C[F]$  needs to satisfy the following properties:

- The local Maxwellian must be a fixed point

$$C[F_M] = 0$$

That is, the collision will not change the local Maxwellian

- Relaxation to the local Maxwellian must happen on a time-scale  $\sim \tau_c$
- Conservation laws must be satisfied.

The simplest model that satisfies this is:

$$\boxed{C[F] = -\frac{F - F_M}{\tau_c} = -\frac{1}{\tau_c} \delta F} \quad (2.32)$$

This is known as *Krook's Collision Operator*.

## 2.6.2 Conservation Laws

Now that we have an equation for the evolution of the local distributions, we can use it to derive some local conservation equations for the gas. We assume that there is some mean flow  $\underline{u} = u_x \hat{x}$ , and define  $\underline{w}$  as the *peculiar velocity* (the difference between the velocity of the particle and the mean flow).

- Number Density

$$\begin{aligned} \frac{\partial n}{\partial t} &= \frac{\partial}{\partial t} \int d^3 \underline{v} F \\ &= \int d^3 \underline{v} \left( -v_z \frac{\partial F}{\partial z} + C[F] \right) \\ &= - \underbrace{\frac{\partial}{\partial z} \int d^3 \underline{v} v_z F}_{\text{no mean velocity in } z \text{ direction}} + \underbrace{\int d^3 \underline{v} C[F]}_{\text{collisions do not change particle no.}} \end{aligned}$$

This means we obtain the expected result of

$$\frac{\partial n}{\partial t} = 0 \quad \longrightarrow \quad n = \text{const}$$

- Momentum Density

$$\begin{aligned} \frac{\partial}{\partial t} (m n u_x) &= \frac{\partial}{\partial t} \int d^3 \underline{v} m v_x F \\ &= \int d^3 \underline{v} m v_x \left( -v_z \frac{\partial F}{\partial z} + C[F] \right) \\ &= - \frac{\partial}{\partial z} \underbrace{\int d^3 \underline{v} m v_x v_z F}_{= \text{total } \Pi_{zx} \text{ by definition}} + \underbrace{\int d^3 \underline{v} m v_x C[F]}_{\text{momentum is conserved}} \end{aligned}$$

Again, we obtain the expected result of

$$\frac{\partial}{\partial t} (m n u_x) + \frac{\partial \Pi_{zx}}{\partial z} = 0$$

- Energy Density

$$\varepsilon = \underbrace{\int d^3\underline{v} \frac{1}{2} m v^2 F}_{\text{total kinetic energy}} - \underbrace{\frac{1}{2} m n u_x^2}_{\text{energy of mean flow}}$$

As we are interested in the *local* conservation, we need to subtract the 'macroscopic' energy of the mean flow.

$$\begin{aligned} \frac{\partial \varepsilon}{\partial t} &= \frac{\partial}{\partial t} \left( \int d^3\underline{v} \frac{1}{2} m v^2 F - \frac{1}{2} m n u_x^2 \right) \\ &= \int d^3\underline{v} \frac{1}{2} m v^2 \left( -v_z \frac{\partial F}{\partial z} + C[F] \right) - m n u_x \frac{\partial u_x}{\partial t} \\ &= -\frac{\partial}{\partial t} \int d^3\underline{v} \frac{1}{2} m v^2 v_z F + u_x \frac{\partial \Pi_{zx}}{\partial z} \end{aligned}$$

Let  $\underline{v} = u_x \hat{x} + \underline{w}$ .

$$\begin{aligned} \int d^3\underline{v} \frac{1}{2} m v^2 v_z F &= \int d^3\underline{w} F w_z \left( \frac{1}{2} m u_x^2 + \frac{1}{2} m w^2 + m u_x w_x \right) \\ &= \int d^3\underline{w} \frac{1}{2} m w^2 w_x F + u_x \int d^3\underline{w} m w_x w_z F \\ &= J_z + u_x \Pi_{zx} \end{aligned}$$

This means we obtain

$$\frac{\partial \varepsilon}{\partial t} + \frac{\partial J_z}{\partial z} = -\Pi_{zx} \frac{\partial u_x}{\partial z}$$

The last term is the result of viscous heating due to the mean flow of the gas; we can obtain the same conservation equation used to derive (2.26) by letting  $u_x = 0$

### 2.6.3 Self-Diffusion 2.0

Using this powerful apparatus that we have now obtained, let us examine the problem of self-diffusion again. Let us compare the relative magnitude of the terms in (2.31). We know that  $\delta F \ll F_M$ , and that variations in  $\delta F$  occur over very large time-scales as supposed to those of  $F_M$ .

$$\begin{aligned} \frac{\partial}{\partial t} &\sim \frac{v_{th} \lambda_{mfp}}{\ell^2} \sim \frac{v_{th}}{\ell} \frac{\lambda_{mfp}}{\ell} \\ v &\sim v_{th} \end{aligned}$$

for some characteristic length of the system  $\ell \gg \lambda_{mfp}$ . This means that we can neglect the first term

$$\boxed{\delta F \approx -\tau_c \underline{v} \cdot \nabla F_M} \quad (2.33)$$

Suppose that, as before, we have a number of labelled particles  $n^*$  of mass  $m^*$  within the gas, with distribution  $F^*$  that satisfies (2.31). Integrating this over all space:

$$\begin{aligned} \int d^3\underline{v} \left( \frac{\partial F^*}{\partial t} + \underline{v} \cdot \nabla F^* \right) &= -\frac{1}{\tau_c} \int d^3\underline{v} \delta F^* \\ \frac{\partial}{\partial t} \int d^3\underline{v} F^* + \nabla \cdot \int d^3\underline{v} \underline{v} F^* &= -\frac{1}{\tau_c} \int d^3\underline{v} \delta F^* \\ \frac{\partial n^*}{\partial t} + \nabla \cdot \left( \int d^3\underline{v} \underline{v} F^* \right) &= 0 \end{aligned}$$

by the definition of  $\delta F^*$ .

$$\begin{aligned}\int d^3\underline{v} \underline{v} F^* &= \int d^3\underline{v} \underline{v} (F_M^* + \delta F^*) \\ &= \int d^3\underline{v} \underline{v} \delta F^*\end{aligned}$$

as the mean velocity for  $F_M^*$  is zero. Using (2.33),

$$\begin{aligned}\int d^3\underline{v} \underline{v} \delta F^* &= \int d^3\underline{v} \underline{v} \cdot (-\tau_c \underline{v} \nabla F_M) \\ &= -\tau_c \int d^3\underline{v} v^2 \nabla F_M^* \\ &= -\tau_c \nabla \int d^3\underline{v} v^2 F_M^* \\ &= -\tau_c \langle v^2 \rangle \nabla n^*\end{aligned}$$

This means the equation becomes

$$\begin{aligned}\frac{\partial n^*}{\partial t} - \tau_c \langle v^2 \rangle \nabla \cdot (\nabla n^*) &= 0 \\ \frac{\partial n^*}{\partial t} &= D^* \nabla^2 n^*\end{aligned}$$

where  $D^* = \tau_c \langle v^2 \rangle$  is the expression for the self-diffusion coefficient. This expression is evidently the exact one, rather than the approximate one that we found in Section (2.5.3).

We can take the first moment of the Kinetic Equation in order to find the momentum conservation equation of the labelled particles.

$$\begin{aligned}\frac{\partial}{\partial t} \int d^3\underline{v} m^* \underline{v} F^* &= - \int d^3\underline{v} (m^* \underline{v}) (\underline{v} \nabla F^*) + \int d^3\underline{v} m^* \underline{v} C[F^*] \\ \frac{\partial}{\partial t} (m^* n^* \underline{u}^*) &= -\nabla \int d^3\underline{v} m v^2 F^* - \frac{1}{\tau_c} \int d^3\underline{v} (F^* - F_M^*) m^* \underline{v} \\ &= -m^* n^* \nabla \langle v^2 \rangle - \frac{1}{\tau_c} m^* n^* \underline{u}^*\end{aligned}$$

Thus, we obtain a result that we have all known since secondary school; that the magnitude of friction is proportional to velocity, and that it acts in the opposite direction to the motion.

$$F_{\text{friction}} = -\frac{1}{\tau_c} m^* n^* \underline{u}^*$$

### 3. *Statistical Mechanics*

This chapter aims to cover the basics of Statistical Mechanics, including:

- Basic Principles
- The Canonical Ensemble
- The Ideal Gas
- The Grand Canonical Ensemble
- Quantum Gases
- The Photon Gas

Arguably, Statistical Mechanics is one of the most powerful pieces of physics that one learns as an undergraduate. Evidently, Quantum Mechanics will always give the correct answer, but it will become increasingly difficult - and almost impossible - to compute the required problem. Statistical Mechanics provides an elegant solution to this, allowing one to treat a large variety of relatively complex systems without much thought actually being given to the small details of the problem. This author certainly enjoyed this course immensely, and hopes that this is reflected in these notes.

### 3.1 Basic Principles

Evidently, as we saw in Chapter (1), Thermodynamics allows us to make a large set of predictions about a system; it can give us the equation of state, the entropy, the energy, the heat capacity, and so on. However, in order to be able to write down the important equations

$$dU = TdS - pdV \quad \text{and} \quad dF = -SdT - pdV$$

we have to have some knowledge about various aspects of the system. For ideal gases, we can get this from Kinetic Theory, but we need to be able to extend this kind of formalism to other systems. This is where Statistical Mechanics comes in.

#### 3.1.1 States of a System

Suppose that a system consists of  $\Omega$  *microstates* (that is, a possible states of all the particles of the system), where for each microstate  $\alpha$  we have an associated probability  $p_\alpha$ , and associated energy  $E_\alpha$ . It is evident that  $\Omega \gg 1$  for an macroscopically defined system due to the sheer number of particles and possible energies involved. This means that we can define certain quantities of the system in terms of their mean quantities, such as the *mean energy*:

$$U = \sum_{\alpha} p_{\alpha} E_{\alpha} \quad (3.1)$$

Evidently, this is where the statistical nature of this subject comes in; we recognise that we cannot know the exact energy of the system, and settle instead on trying to calculate the mean energy. Note that we evidently require the probabilities are properly normalised, namely that  $\sum_{\alpha} p_{\alpha} = 1$ .

#### Pressure

From this, we can immediately derive an expression for pressure in this formalism. Consider an system undergoing some adiabatic process. From Quantum Mechanics, we know that in adiabatic processes, the system remains in a state of well defined energy during the process (assuming it was already in a state of well-defined energy), which means that the microstates  $\alpha$  of the system do not change. From (1.17), we can write that

$$dU_{\text{adiabatic}} = \left( \frac{\partial U}{\partial V} \right)_{p_1, \dots, p_{\Omega}} dV = \sum_{\alpha} p_{\alpha} \frac{\partial E_{\alpha}}{\partial V} dV$$

However, during an adiabatic process, we know that  $dU = -pdV$ . This means that we can simply define the pressure as

$$p = - \sum_{\alpha} p_{\alpha} \frac{\partial E_{\alpha}}{\partial V} \quad (3.2)$$

This kind of calculation can also be repeated for non- $pV$  systems. This means that if we were able to know the complete sets  $\{p_{\alpha}\}$  and  $\{E_{\alpha}\}$ , we would be able to calculate this quantity explicitly.

#### 3.1.2 Gibbs Entropy

The next logical question to ask is as to how to calculate these  $\{p_{\alpha}\}$  given that we know the set of energies  $\{E_{\alpha}\}$ . Knowing the latter is not too difficult, as this can be given to us from Quantum Mechanics without much trouble. What about the  $\{p_{\alpha}\}$ ? Suppose that we

know nothing about our system at all. In this case, the system must be isolated, as otherwise we would be able to gain some information about the system from how it interacts with its surroundings. The only fair way to assign probabilities to the microstates of the system is to say that they are equally likely; we have no information to tell us otherwise. This leads us to the important statistical mechanics inference that *for an isolated system in equilibrium, all microstates are equally likely*.

Suppose that our system consists of  $N$  particles, where  $N \gg \Omega$ . Now, let us randomly assign each of the  $N$  particles to the microstates  $\{\alpha\}$ , in a similar way to randomly throwing marbles into a very large set of boxes. In this way, we arrive at having  $N_\alpha$  particles in the microstate  $\alpha$ , and associated probability

$$p_\alpha = \frac{N_\alpha}{N} \quad \text{for} \quad \sum_\alpha N_\alpha = N$$

Now what is the most likely outcome of our assignment  $\{N_\alpha\}$ ? The number of ways  $E$  of carrying out our un-ordered assignment is given by

$$W = \frac{N!}{N_1! \dots N_\Omega!}$$

As we have no information about the system to tell us that any such assignment is more likely than another, all outcomes are equally probable. This means that the most likely outcome for  $\{N_\alpha\}$  will be the one that maximises  $W$ , or rather  $\log W$ . We will make extensive use of (3.5).

$$\begin{aligned} \log W &= \log N! - \log (N_1! \dots N_\Omega!) \\ &\sim N \log N - N - \sum_\alpha (N_\alpha \log N_\alpha - N_\alpha) \\ &= - \sum_\alpha N_\alpha \log \left( \frac{N_\alpha}{N} \right) \end{aligned}$$

Recalling the definition of  $p_\alpha$  above, and dividing through by  $N$ , we arrive at the expression

$$\boxed{S_G = - \sum_\alpha p_\alpha \log p_\alpha} \quad (3.3)$$

This is known as the *Gibbs Entropy* of a system. We will see its full significance shortly, but for now, we understand it as a function that is related to the possible assignments of particles to microstates within a given system.

### 3.1.3 Entropy Maximisation

In the previous section, we supposed that the most likely outcome for our assignment  $\{N_\alpha\}$  will be that maximises  $\log W$ . This corresponds directly to  $S_G$  being maximised, subject to a set of constraints  $F_i = 0$  that correspond to our knowledge about the system. This means that we want to maximise

$$S_G - \sum_{i=1}^m \lambda_i F_i$$

unconditionally with respect to  $\Omega + m$  variables

$$p_1, \dots, p_\Omega, \quad \underbrace{\lambda_1, \dots, \lambda_m}_{\text{Lagrange Multipliers}}$$

such that  $m \leq \Omega$ . This is because the number of constraints cannot be greater than the number of microstates, as  $m = \Omega$  corresponds to total knowledge of the system. In reality,  $m \ll \Omega$  as we are limited by our knowledge of the system.

Let us suppose that we are completely ignorant about our system; we know that it exists, but we really don't know anything about it. This means that the only constraint that we can place on  $S_G$  is

$$\lambda \left( \sum_{\alpha} p_{\alpha} - 1 \right) = 0 \quad (3.4)$$

Maximising unconditionally:

$$\begin{aligned} dS_G - d\lambda \left( \sum_{\alpha} p_{\alpha} - 1 \right) - \lambda \sum_{\alpha} dp_{\alpha} &= 0 \\ - \sum_{\alpha} (\log p_{\alpha} + 1 + \lambda) dp_{\alpha} - d\lambda \left( \sum_{\alpha} p_{\alpha} - 1 \right) &= 0 \end{aligned}$$

Setting each of these terms individually to zero:

$$\begin{aligned} \log p_{\alpha} + 1 + \lambda &= 0 \\ p_{\alpha} &= e^{-(1+\lambda)} \\ \sum_{\alpha} \underbrace{e^{-(1+\lambda)}}_{\text{independent of } \alpha} &= 1 \\ \rightarrow p_{\alpha} &= \frac{1}{\Omega} \end{aligned}$$

Thus, we confirm our assumption in the previous section that the microstates of an isolated system in equilibrium are all equally likely.

### 3.1.4 Stirling's Formula

Before moving on, it would be worth introducing *Stirling's Formula* due to all the large logarithmic factors that we will be dealing with. It states that

$$\boxed{\log N! \sim N \log N - N} \quad (3.5)$$

assuming that  $N$  is sufficiently large. In fact, it turns out that  $N \sim 50$  is enough to reduce the error in using this formula to 2%, so in the Thermodynamic limit, this is essentially an exact expression.

In order to prove this formula, we need to consider the integral expression for  $N!$ , namely

$$N! = \int_0^{\infty} dx x^N e^{-x}$$

This integral evidently has a maximum, as it tends to zero as  $x \rightarrow \infty$ , and is zero for  $x = 0$ . Let us expand the integrand around the maximum. Let

$$\begin{aligned} e^{f(x)} &= x^N e^{-x} \\ f(x) &= N \log(x) - x \end{aligned}$$

Taking the first and second derivatives:

$$\begin{aligned}\frac{\partial f}{\partial x} &= \frac{N}{x} - 1 \\ \frac{\partial^2 f}{\partial x^2} &= -\frac{N}{x^2}\end{aligned}$$

This means that the maximum of the integrand will occur at  $x = N$ . We can thus Taylor expand the integrand as

$$\begin{aligned}N! &= \int_0^\infty dx e^{f(x)} \\ &= e^{N \log N - N} \int_0^\infty dx e^{-\frac{1}{2N}(x-N)^2 + \dots} \\ &\sim e^{N \log N - N} \sqrt{2\pi N}\end{aligned}$$

where we have used the fact that we can extend the integral range to  $[-\infty, \infty]$  as the contribution from the negative part of the integral becomes vanishingly small for large  $N$  (width scales as  $\sqrt{N}$ ). It follows that

$$\log N! \sim N \log N - N + \frac{1}{2} \log(2\pi N)$$

If  $N$  is sufficiently large, we can ignore the last term, as it scales as  $\log N$  rather than as  $N$ . We thus arrive the result quoted above.

### 3.2 The Canonical Ensemble

Suppose that the mean energy of the system is fixed. This means that we now add the constraint that

$$\beta \left( \sum_{\alpha} p_{\alpha} E_{\alpha} - U \right) = 0 \quad (3.6)$$

In this ensemble, we are going to treat both the volume  $V$  and the number of particles  $N$  as *exact external parameters*, as supposed to some mean property to be measured. Maximising  $S_G$  unconditionally with respect to both constraints:

$$- \sum_{\alpha} (\log p_{\alpha} + 1 + \lambda + \beta E_{\alpha}) dp_{\alpha} - d\lambda \left( \sum_{\alpha} p_{\alpha} - 1 \right) - \beta \left( \sum_{\alpha} p_{\alpha} E_{\alpha} - U \right) = 0$$

Setting each of the terms identically to zero:

$$\begin{aligned} \log p_{\alpha} = -1 - \lambda - \beta E_{\alpha} &\longrightarrow p_{\alpha} = e^{-(1+\lambda+\beta E_{\alpha})} \\ \sum_{\alpha} e^{-(1+\lambda+\beta E_{\alpha})} = 1 &\longrightarrow e^{-(1+\lambda)} = \frac{1}{\sum_{\alpha} e^{-\beta E_{\alpha}}} \end{aligned}$$

Putting these two expressions together, we find that the probability of a particular microstate  $\alpha$  is given by

$$p_{\alpha} = \frac{e^{-\beta E_{\alpha}}}{Z(\beta)} \quad \text{for} \quad Z(\beta) = \sum_{\alpha} e^{-\beta E_{\alpha}} \quad (3.7)$$

We give this the name *the canonical ensemble*, where  $Z(\beta)$  is a normalisation constant known as the *partition function*. This means that if we know all  $E_{\alpha}$ 's, we can calculate the probability of each microstate from this expression.

We are now going to examine the question of the significance of our Lagrange multiplier  $\beta$ . Substitute our new-found expression for  $p_{\alpha}$  into the normal expression for  $S_G$ .

$$S_G = - \sum_{\alpha} p_{\alpha} \log p_{\alpha} = - \sum_{\alpha} \frac{1}{Z} e^{-\beta E_{\alpha}} \log \left( \frac{1}{Z} e^{-\beta E_{\alpha}} \right) = \beta U + \log(Z)$$

Calculating the total derivative:

$$\begin{aligned} dS_G &= U d\beta + \beta dU + \frac{dZ}{Z} \\ &= U d\beta + \beta dU - \frac{1}{Z} \sum_{\alpha} e^{-\beta E_{\alpha}} (\beta dE_{\alpha} + E_{\alpha} d\beta) \\ &= \cancel{U d\beta} + \beta dU - \sum_{\alpha} p_{\alpha} (\beta dE_{\alpha} + \cancel{E_{\alpha} d\beta}) \\ &= \beta dU - \beta \sum_{\alpha} p_{\alpha} dE_{\alpha} \end{aligned}$$

Recalling (3.2), this reduces to

$$S_G = \beta \underbrace{(dU + pdV)}_{\dots \text{First Law!}} = \beta dQ_{rev}$$

We now impose the condition that  $dS = k_B dS_G$ , where  $S$  is our conventional Thermodynamic entropy. Then, by the definition of  $dQ_{rev}$ , we find that

$$\boxed{\beta = \frac{1}{k_B T}} \quad (3.8)$$

Thus, the Lagrange Multiplier that we impose along with the constraint on the mean energy turns out to be inverse temperature! Note that it has units of energy, such that the partition function remains dimensionless.

### 3.2.1 Some Important Relationships

Our formalism is thus clear: maximise entropy subject to constraints, find the distribution, find the partition function, relate to thermodynamic quantities through entropy, and differentiate to find everything. The partition function is all we really need for Thermodynamics, which is what makes Statistical Mechanics such a powerful tool. Now that we have an expression for  $\beta$ , we can now derive some useful thermodynamic quantities from our partition function  $Z(\beta)$ .

#### Mean Energy

Using our statistical definition of the mean energy  $U$ :

$$\begin{aligned} U &= \sum_{\alpha} p_{\alpha} E_{\alpha} \\ &= \sum_{\alpha} \frac{1}{Z} e^{-\beta E_{\alpha}} E_{\alpha} \\ &= - \sum_{\alpha} \frac{1}{Z} \frac{\partial}{\partial \beta} (e^{-\beta E_{\alpha}}) \end{aligned}$$

This means that the mean energy is calculated from the partition function as

$$\boxed{U = - \frac{\partial \log(Z)}{\partial \beta}} \quad (3.9)$$

#### Heat Capacity

At this stage, it would be useful to find a relationship between derivatives with respect to  $T$  and those with respect to  $\beta$ , as we work mainly with the former in Thermodynamics, and the latter in Statistical Mechanics. From the definition of  $\beta$ :

$$\frac{\partial \beta}{\partial T} = - \frac{1}{k_B T^2} \quad \rightarrow \quad \frac{\partial}{\partial T} = - \frac{\beta}{T} \frac{\partial}{\partial \beta}$$

We can use this relationship to find an expression for heat capacity at constant volume.

$$C_V = \left( \frac{\partial U}{\partial T} \right) = - \frac{\beta}{T} \left( \frac{\partial U}{\partial \beta} \right)_V$$

Substituting our definition of  $U$  from above, we arrive at

$$\boxed{C_V = \frac{\beta}{T} \frac{\partial^2 \log(Z)}{\partial \beta^2}} \quad (3.10)$$

Let us compute this expression explicitly from  $Z(\beta)$ .

$$\begin{aligned}\frac{\partial^2 \log(Z)}{\partial \beta^2} &= \frac{\partial}{\partial \beta} \left( -\frac{1}{Z} \sum_{\alpha} E_{\alpha} e^{-\beta E_{\alpha}} \right) \\ &= \frac{1}{Z} \sum_{\alpha} E_{\alpha}^2 e^{-\beta E_{\alpha}} - \frac{1}{Z^2} \left( \sum_{\alpha} E_{\alpha} e^{-\beta E_{\alpha}} \right) \left( \sum_{\gamma} E_{\gamma} e^{-\beta E_{\gamma}} \right) \\ &= \sum_{\alpha} p_{\alpha} E_{\alpha}^2 - \left( \sum_{\alpha} p_{\alpha} E_{\alpha} \right) \left( \sum_{\gamma} p_{\gamma} E_{\gamma} \right)\end{aligned}$$

Recalling our definition of the expectation value of some quantity, we see that the above expression is clearly the variance of the energy  $\langle (\Delta E)^2 \rangle$ . Thus, another way of expressing the heat capacity is

$$C_V = \frac{(\Delta E)^2}{k_B T^2} \geq 0$$

Clearly, a system will only be stable for  $C_V \geq 0$ , as otherwise it would be able to increase its temperature arbitrarily. We examine similar conditions in Section (3.2.2).

### Entropy and Helmholtz Free Energy

Using the partition function, have already found the relationship that

$$S_G = \beta U + \log(Z)$$

This means that we can write the Thermodynamic entropy of the system as

$$\boxed{S = \frac{U}{T} + k_B \log(Z)} \quad (3.11)$$

This expression is always greater than or equal to zero, as  $Z > 0$  for probabilities to be well-defined (positive). It then follows that:

$$\boxed{F = U - TS = -k_B T \log(Z)}$$

We can take the usual derivatives of  $F$  with respect to various variables to find the desired quantities, such as entropy ( $T$ ) or pressure ( $V$ ). This means that often the hardest part about Statistical Mechanics is finding the partition function; the rest is merely taking derivatives!

### 3.2.2 Stability and Equilibria

We are now going to derive the conditions that are required for a system to be in equilibrium. Suppose that we have a system that is made up of a series of subsystems indexed by  $i$ , that have the quantities:

- $\varepsilon_i$  total energy
- $m_i$  mass
- $\underline{u}_i$  velocity
- $\underline{r}_i$  centre of mass
- $V_i$  volume

As entropy is additive, the entropy of the total system is the sum of the entropy of the individual systems; that is:

$$S = \sum_i S_i$$

Note that  $S_i$  can only depend on the internal energy of the sub-system, as the total energy of the total system is conserved. This means that  $S_i = S_i(U_i, V_i)$ , where  $U_i$  is the internal energy of the system (the difference between the total and kinetic energy).

We thus want to maximise the total entropy with respect to the following conservation laws:

$$\begin{aligned} \delta \left( \sum_i \varepsilon_i - \varepsilon \right) &= 0 \\ \underline{a} \cdot \left( \sum_i m_i \underline{u}_i - \underline{p} \right) &= 0 \\ \underline{b} \cdot \left( \sum_i m_i \underline{r}_i \times \underline{u}_i - \underline{L} \right) &= 0 \\ \sigma \left( \sum_i V_i - V \right) &= 0 \end{aligned}$$

We are not going to try and assign any significance to the Lagrange multipliers used, as they are completely arbitrary, with  $\delta = k_B \beta$  being the notable exception.

## Equilibria

Maximising the expression for entropy and requiring that all of the individual constraints are zero allows us to obtain relationships between the quantities in each of our subsystems.

- Thermal Equilibrium:

$$\frac{\partial S_i}{\partial \varepsilon_i} = \frac{\partial S_i}{\partial U_i} = \frac{1}{T_i} \longrightarrow \frac{1}{T_i} = \delta = \frac{1}{T}$$

This means that the condition for the subsystems to be in thermal equilibrium is if their *temperatures are the same*, as anticipated by the Zeroth Law of Thermodynamics

- Mechanical Equilibrium:

$$\frac{\partial S_i}{\partial V_i} = \frac{p_i}{T_i} \longrightarrow p_i = \frac{\sigma}{\delta}$$

This means that the condition for the subsystems to be in mechanical equilibrium is if the *pressures within them are the same*, meaning that the pressures are balanced at the boundaries

- Dynamical Equilibrium:

$$\frac{\partial S}{\partial \underline{u}_i} = \frac{\partial S}{\partial U_i} \frac{\partial U_i}{\partial \underline{u}_i} = -m_i \underline{u}_i \frac{1}{T_i} \longrightarrow m_i \delta \underline{u}_i = -m_i (\underline{a} + \underline{b} \times \underline{r}_i)$$

This means that we can write  $\underline{u}_i = \underline{u} + \underline{\Omega} \times \underline{r}_i$ , where  $\underline{u}$  represents constant translational motion, while  $\underline{\Omega} \times \underline{r}_i$  represents rigid rotation.

This means that in equilibrium, we cannot have an gradients of temperature, pressure, or velocity inside the total system, as we could have anticipated.

## Stability

The stability of the systems comes from looking at further derivatives of  $S$ . This is because we do not in fact know whether the extremum found when maximising  $S$  was a maximum, minimum, or saddle point.

- Thermal Stability:

$$\frac{\partial^2 S_i}{\partial \varepsilon_i^2} = \frac{\partial}{\partial \varepsilon_i} \left( \frac{1}{T} \right) = -\frac{1}{T^2} \frac{\partial T}{\partial \varepsilon_i} = -\frac{1}{T^2} \frac{\partial T}{\partial U_i} = -\frac{1}{C_V T^2}$$

We have thus found that this is a maximum as  $C_V \geq 0$  (proven above)

- Dynamical Stability:

$$\frac{\partial S_i}{\partial U_i} = \frac{1}{T}$$

Suppose that  $T < 0$ . Then, this means that all  $S_i$ 's would be maximised by decreasing their argument as much as possible; that is, by increasing their kinetic energy, flying off to infinity. This means that *temperature must be positive* for dynamical stability. Note that this restriction does not apply for systems whose motion is constrained, and prevented from flying apart (such as a chain of molecules)

### 3.2.3 Some Common Examples

Let us now examine two common systems that can be treated with the Canonical Ensemble. These will come up many times in this course, as they can be applied to describe the behaviour of a large variety of systems.

Before we do so, a quick note about systems that are composed of many individual units, such as the particles in a gas, or atoms within a lattice. Assuming that these units are distinguishable, the partition function of the composite system is given by

$$Z(\beta) = Z_1^N \quad (3.12)$$

This follows from the definition of probabilities; the probability  $p_\alpha$  of having  $N$  particles in a state  $\alpha$  is given by  $p'_\alpha{}^N$  (where  $p'_\alpha$  is the probability for a single unit), meaning that the partition function must be modified in the above way. We will come back to how one handles indistinguishable units in a later section.

### The Two-Level System

Suppose that we have a system that has two energy levels,  $+\Delta$  and  $-\Delta$ . Then, the partition function for the system is clearly

$$Z_1(\beta) = \sum_{\alpha} e^{-\beta E_{\alpha}} = e^{\beta\Delta} + e^{-\beta\Delta} = 2 \cosh(\beta\Delta)$$

The most common system that we can apply this partition function to is that of a *spin- $\frac{1}{2}$  paramagnet*, with energy levels  $\pm\mu_B B$ . Suppose that we have  $N$  spin- $\frac{1}{2}$  particles within our system. Then the partition function for the entire system is given by

$$\boxed{Z(\beta) = 2^N \cosh^N(\beta\mu_B B)} \quad (3.13)$$

The quantity we are most often interested in with the spin- $\frac{1}{2}$  paramagnet is its heat capacity  $C_V$ . Using (3.9):

$$U = -N\mu_B B \tanh(\beta\mu_B B) = -\frac{1}{2}Nk_B\Theta_B \tanh\left(\frac{\Theta_B}{2T}\right)$$

where we have defined  $\Theta_B = \frac{2\mu_B B}{k_B}$ , which is the excitation temperature for the paramagnetic effects. From the definition of heat capacity, we find that

$$C_B = \left(\frac{\partial U}{\partial T}\right)_B = Nk_B \left(\frac{\Theta_B}{T}\right)^2 \frac{e^{\Theta_B/T}}{(e^{\Theta_B/T} + 1)^2}$$

Let us look at some limits of this expression.

- High Temperature Limit ( $T \gg \Theta_B$ ):

$$e^{\Theta_B/T} \sim 1 \longrightarrow c_B \propto \frac{1}{T^2}$$

- High Temperature Limit ( $T \ll \Theta_B$ ):

$$e^{\Theta_B/T} \gg 1 \longrightarrow c_B \propto \frac{1}{T^2} e^{-\Theta/T}$$

As  $C_B$  tends to zero in both limits, this means that there must be some maximum temperature for which the magnetic heat capacity of the system is maximised. This turns out to be around  $\sim 5.6K$ .

For the magnetisation, we need our expression for the Helmholtz free energy as

$$F = U - TS - \underline{m} \cdot \underline{B}$$

where  $m = \underline{M}V$  is the *magnetic moment*. This means that the magnetisation can be easily obtained as

$$M = -\frac{1}{V} \left(\frac{\partial F}{\partial B}\right)_T = \frac{N\mu_B}{V} \tanh\left(\frac{\mu_B B}{k_B T}\right)$$

This once again behaves sensibly; we re-obtain Curie's Law in the high temperature limit, and find that the magnetisation is constant in the low temperature limit.

### The Harmonic Oscillator

We know from Quantum Mechanics that the energy levels of a 1-D harmonic oscillator are

$$E_n = \left(n + \frac{1}{2}\right) \hbar\omega$$

This means that the partition function is given by

$$Z_1(\beta) = \sum_{\alpha} e^{-\beta E_{\alpha}} = \sum_{n=0}^{\infty} e^{-(n+\frac{1}{2})\beta\hbar\omega} = e^{-\frac{1}{2}\beta\hbar\omega} \sum_{n=0}^{\infty} e^{-n\beta\hbar\omega}$$

We can sum the last term as an infinite geometric series to obtain

$$\boxed{Z_1(\beta) = \frac{e^{-\frac{1}{2}\beta\hbar\omega}}{1 - e^{-\beta\hbar\omega}}} \quad (3.14)$$

This expression is actually used within the Einstein model of the heat capacity of solids. All atoms are considered to be independent simple harmonic oscillators all vibrating in three dimensions at the same angular frequency  $\omega$ . Note that there is some constant energy  $U_0$  in the Hamiltonian of the system, but we are going to ignore this as it does not effect the properties of the solid (apart from the mean energy). The result  $Z_1$  above is for a single oscillator in 1-D. For  $N$  particles in a 3-D lattice, it follows that

$$Z(\beta) = (Z^{1D})^3 = (Z_1^N)^3 = Z_1^{3N}$$

Recalling (3.10), we find that

$$C_V = 3Nk_B(\beta\hbar\omega)^2 \frac{e^{\beta\hbar\omega}}{(e^{\beta\hbar\omega} - 1)^2}$$

At high temperatures,  $\beta\hbar\omega \ll 1$ , such that  $e^{\beta\hbar\omega} \sim 1 + \beta\hbar\omega$ . This means that we obtain  $C_V = 3Nk_B$  in the high temperature limit.

### 3.3 The Grand Canonical Ensemble

We are now going to make  $N$  (the number of particles) a variable parameter within our formalism, such that we can treat systems where numbers of particles are exchanged, or where there are various inhomogeneities. This means that we have to introduce a further constraint of

$$-\beta\mu \left( \sum_{\alpha} p_{\alpha} N_{\alpha} - \bar{N} \right) = 0 \quad (3.15)$$

where  $\bar{N}$  is the mean particle number for the system. Following the familiar maximisation process, we find that

$$p_{\alpha} = \frac{e^{-\beta(E_{\alpha} - \mu N_{\alpha})}}{\mathcal{Z}(\beta, \mu)} \quad \text{for} \quad \mathcal{Z}(\beta, \mu) = \sum_{\alpha} e^{-\beta(E_{\alpha} - \mu N_{\alpha})} \quad (3.16)$$

This is known as the *grand canonical ensemble*, with  $\mathcal{Z}(\beta, \mu)$  being the *grand partition function*. We can re-obtain the canonical ensemble by letting  $N_{\alpha} = N$  (all energy levels have equal numbers of particles).

#### 3.3.1 Chemical Potential

In a similar fashion to Section (3.2), we want to give some meaning to our new Lagrange multiplier  $\mu$ . Substitute (3.16) into the normal expression for  $S_G$ .

$$S_G = - \sum_{\alpha} p_{\alpha} [-\beta(E_{\alpha} - \mu N_{\alpha}) - \log(\mathcal{Z})] = \beta U - \beta\mu\bar{N} + \log(\mathcal{Z})$$

Taking the total derivative:

$$\begin{aligned} dS_G &= \beta dU - \beta\mu d\bar{N} - \beta\bar{N} d\mu + (U - \mu\bar{N}) d\beta + \frac{d\mathcal{Z}}{\mathcal{Z}} \\ \frac{d\mathcal{Z}}{\mathcal{Z}} &= \sum_{\alpha} p_{\alpha} [-\beta(dE_{\alpha} - N_{\alpha} d\mu) - (E_{\alpha} - \mu N_{\alpha}) d\beta] \end{aligned}$$

where we have restricted  $dN_{\alpha} = 0$ . Cancelling terms as shown,

$$dS_G = \beta(dU - \mu d\bar{N}) - \beta \sum_{\alpha} p_{\alpha} dE_{\alpha}$$

Again, letting  $dS = k_B dS_G$ , and using (3.2), we arrive at the equation

$$\boxed{TdS = dU + pdV - \mu\bar{N}} \quad (3.17)$$

This is the *fundamental equation of thermodynamics for open systems*. This means that we can write  $\mu$  as

$$\mu = -T \left( \frac{\partial S}{\partial \bar{N}} \right)_{U, V}$$

We can thus interpret  $-\mu$  as the heat from adding an extra particle to the system at constant  $U$  and  $V$ . This means that  $\mu$  is normally a negative quantity, as it is often thought of as a "cost-per-particle". It is known as the *chemical potential* of a system. Note that we often find  $\mu$  as the implicit solution to an equation for  $\bar{N}$ , which we see in later sections.

Let us now consider the Gibbs Free Energy. Using (1.28) and (3.17), we know that

$$dG = -SdT + Vdp + \mu d\bar{N} \longrightarrow \mu = \left( \frac{\partial G}{\partial \bar{N}} \right)_{p,T}$$

Now,  $G$  and  $\bar{N}$  are both extensive quantities; that is, they depend on the size of the system. This means that if we scale  $\bar{N}$  by some constant  $\lambda$ ,  $G$  must also scale in the same way.

$$G(p, T, \lambda\bar{N}) = \lambda G(p, T, \bar{N})$$

Differentiating with respect to  $\lambda$  and using the chain rule:

$$\left( \frac{\partial G}{\partial(\lambda\bar{N})} \right)_{p,T} \bar{N} = G$$

However, as our choice of  $\lambda$  is arbitrary, this equation must hold for *all*  $\lambda$ . If we set  $\lambda = 1$ , we find that

$$\boxed{\mu = \frac{G}{\bar{N}}} \quad (3.18)$$

This means that the chemical potential can also be thought of as the *Gibbs Free Energy per particle* for a system. This means that it is an intensive quantity, and so that  $\mu = \mu(p, T)$  (as it cannot depend on system size, and thus  $\bar{N}$ ).

### Particle Equilibrium

Suppose that we have two systems of total energy  $U = U_1 + U_2$ , total mean particle number  $\bar{N} = \bar{N}_1 + \bar{N}_2$  and total entropy  $S = S_1 + S_2$  (that we wish to maximise). Then:

$$\begin{aligned} dS &= \frac{\partial S_1}{\partial U_1} dU_1 + \frac{\partial S_1}{\partial \bar{N}_1} d\bar{N}_1 + \frac{\partial S_2}{\partial U_2} dU_2 + \frac{\partial S_2}{\partial \bar{N}_2} d\bar{N}_2 \\ &= \left( \frac{\partial S_1}{\partial U_1} - \frac{\partial S_2}{\partial U_2} \right) + \left( \frac{\partial S_1}{\partial \bar{N}_1} - \frac{\partial S_2}{\partial \bar{N}_2} \right) d\bar{N}_1 \\ &= \left( \frac{1}{T_1} - \frac{1}{T_2} \right) dU_1 + \left( -\frac{\mu_1}{T_1} + \frac{\mu_2}{T_2} \right) d\bar{N}_1 \end{aligned}$$

Setting  $dS = 0$ , we find that when a system is in equilibrium  $T_1 = T_2$  (as before) and  $\mu_1 = \mu_2$ . That latter of these two is known as *chemical equilibrium*. Suppose now that the system is in thermal equilibrium, but not chemical equilibrium.

$$dS = -(\mu_1 - \mu_2) \frac{d\bar{N}_1}{T} > 0$$

This means that  $d\bar{N}_1 > 0$  for  $\mu_2 = \mu_1$ . This means that *matter moves from large to small  $\mu$* . Evidently, the chemical potential is related to the exchange of particles between systems.

### 3.3.2 The Grand Potential

For open systems, we define a new thermodynamic quantity known as *The Grand Potential*, defined as

$$\boxed{\Phi = F - \mu\bar{N} = -k_B T \log(\mathcal{Z}) = -pV} \quad (3.19)$$

The last equality comes from considering (3.18), and simplifying the resultant expression. This is always true, meaning that the equation of state for the system can be found trivially from the Grand Potential. Taking the total derivative:

$$d\Phi = -SdT - pdV - \bar{N}d\mu$$

This results in the relations:

$$S = - \left( \frac{\partial \Phi}{\partial T} \right)_{\mu, V} \quad (3.20)$$

$$p = - \left( \frac{\partial \Phi}{\partial V} \right)_{\mu, T} \quad (3.21)$$

$$\bar{N} = - \left( \frac{\partial \Phi}{\partial \mu} \right)_{T, V} \quad (3.22)$$

Once again, the thermodynamics can simply be extracted from the Grand Potential, which is essentially just the logarithm of the partition function.

### 3.3.3 Multi-species Systems

Now that we have set up our apparatus for dealing with multiple component systems, let us put this into practise. Suppose that we have a system that consists of  $m$  different species that are free to exchange particles and energy with one another. For each microstate of the system  $\alpha$ , let us associate an energy  $E_\alpha$ , and particle numbers

$$N_{1\alpha}, N_{2\alpha}, \dots, N_{m\alpha} \quad \text{with} \quad \mu_1, \mu_2, \dots, \mu_m$$

We are again going to consider the Gibbs Free Energy of the system, and scale by an arbitrary factor  $\lambda$ .

$$G(p, T, \lambda \bar{N}_1, \dots, \lambda \bar{N}_m) = \lambda G(p, T, \bar{N}_1, \dots, \bar{N}_m)$$

Taking the derivative as before and setting  $\lambda = 1$ :

$$\underbrace{\sum_s \frac{\partial G}{\partial (\lambda \bar{N}_s)} \bar{N}_s}_{\text{sum over species}} = G \quad \longrightarrow \quad \sum_s \frac{\partial G}{\partial \bar{N}_s} = G$$

Then, it follows that

$$G = \sum_s \mu_s \bar{N}_s$$

Now consider a chemical reaction between various species. All such reactions can be written as

$$\sum_s \nu_s a_s = 0 \quad (3.23)$$

where  $a_s$  denote the various species, and  $\nu_s$  denote their coefficients in the chemical equation. Conventionally, the products are defined to have negative  $\mu_s$ . For example, the formation of water

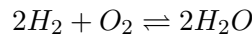

can be written in this form for  $a_1 = H_2$ ,  $\nu_1 = 2$ ,  $a_2 = O_2$ ,  $\nu_2 = 1$ ,  $a_3 = H_2O$ , and  $\nu_3 = -2$ . In the first chapter, we learnt that equilibrium was reached for a system held at a given  $p$  and  $T$  when the Gibbs Free Energy was minimised.

$$dG = \sum_s \mu_s d\bar{N}_s = 0$$

This, along with (3.23), implies that as the chemical reaction progresses

$$d\bar{N}_1 : d\bar{N}_2 : \cdots : d\bar{N}_m = \nu_1 : \nu_2 : \cdots : \nu_m$$

That is, the particle numbers and the coefficients  $\nu_s$  will be in the same ratio. This leads to the very important equation of

$$\boxed{\sum_s \nu_s \mu_s = 0} \quad (3.24)$$

This is one statement of what is known as *The Law of Mass Action*, which determines the behaviour of chemical reactions. We can use this to find the equilibrium concentration of the various components in a multi-species system.

*Given that the chemical potential of a non-relativistic electron/positron gas can be written as*

$$\mu = -k_B T \log \left( (2s+1) \frac{n_Q}{n} \right) \quad \text{where} \quad n_Q = \left( \frac{m_e k_B T}{2\pi \hbar^2} \right)^{3/2}$$

*find the density of positrons created from spontaneous pair-production defined by the equation*

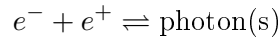

*Remember to take into account the relative concentration of the positron and electron pairs with respect to the density of normal electrons in matter (without pair production)  $n_0$ . Consider briefly the relativistic case.*

Now, we will see the expressions for  $\mu$  and  $n_Q$  in later sections, so do not be too worried about their significance here. If readers find this example a little confusing at this stage, it is recommended that they come back to this when they are familiar with the results of Section (3.4) and (3.5.3). The condition for chemical equilibrium (in both the non-relativistic and relativistic cases) is

$$\mu_- + \mu_+ = \mu_{\text{photon}} = 0$$

Let us actually consider the relativistic case. In this limit, the energy of the system is so high that the number of the electron-positron pairs dominates in comparison to the number of electrons in normal matter, and so we can neglect  $n_0$  as it is very small. This means that the entire system is symmetric, and so that  $\mu_- = \mu_+ = 0$ . The equilibrium concentrations can thus be calculated using the results of Section (3.5.3), though this is left as an exercise for the reader once they have covered Quantum Gases.

In the non-relativistic limit, the energy of the system is much lower, and so we cannot assume that the equilibrium density of the pairs is much greater than  $n_0$ ; in fact, it is most likely going to be much less than  $n_0$ . We now need to take into account the chemical potential that results from the rest mass. Letting  $s = \frac{1}{2}$  for electrons and positrons (as these are spin- $\frac{1}{2}$  particles), their chemical potentials are

$$\begin{aligned} \mu_- &= -k_B T \log \left( \frac{2n_Q}{n_-} \right) + m_e c^2 \\ \mu_+ &= -k_B T \log \left( \frac{2n_Q}{n_+} \right) + m_e c^2 \end{aligned}$$

If we now apply the condition for chemical equilibrium for the system from above, we find that

$$k_B T \log \left( \frac{4n_Q^2}{n_- n_+} \right) = 2m_e c^2$$

$$\frac{4n_Q^2}{n_- n_+} = e^{-(2m_e c^2)/(k_B T)}$$

As  $n_0 \gg n_+$ , we can write  $n_- = n_+ + n_0 \sim n_0$  (this equality comes from the fact that the density of pairs must be the same, taking into account the concentration in normal matter). This means that the equilibrium concentration of the positrons is given by

$$n^+ \sim \frac{4}{n_0} \left( \frac{m_e k_B T}{2\pi \hbar^2} \right)^3 e^{-(2m_e c^2)/(k_B T)}$$

This author tried calculating this value (estimating  $n_0 \sim a_0^{-3}$ , where  $a_0$  is the Bohr radius), but it came out to be zero. This is because the factor in the exponential is on the order of  $10^7$ , which dominates the cubic expression.

### 3.4 The Ideal Gas

We will first treat the Ideal Gas using the Canonical Ensemble. If we treat the ideal gas classically, it's energy levels are given by

$$\varepsilon_k = \frac{\hbar^2 k^2}{2m}$$

Theoretically, we could just plug this expression into (3.7) and obtain the partition function. However, the problem that we encounter is that sums of this type are very difficult to calculate; it is much easier to calculate an equivalent integral. Suppose that our system is a box with side lengths  $L_x, L_y, L_z$ . Then, we are restricted to the wavenumbers that satisfy

$$\underline{k} = \left( \frac{2\pi}{L_x} i_x, \frac{2\pi}{L_y} i_y, \frac{2\pi}{L_z} i_z \right)$$

for integers  $i_x, i_y, i_z$  in order to fulfil appropriate (periodic) boundary conditions at the extremities of the box. This means that  $\Delta k_{x,y,z} = (2\pi)/(L_{x,y,z})$  represents the mesh-size (spacing between discrete grid points) in phase-space. Then, we can approximate the desired sum by an integral:

$$Z_1 = \sum_{\underline{k}} e^{-\beta\varepsilon_k} = \sum_{\underline{k}} \underbrace{\frac{L_x L_y L_z}{(2\pi)^3}}_{\frac{V}{(2\pi)^3}} \underbrace{\frac{2\pi}{L_x}}_{\Delta k_x} \underbrace{\frac{2\pi}{L_y}}_{\Delta k_y} \underbrace{\frac{2\pi}{L_z}}_{\Delta k_z} e^{-\beta\varepsilon_k} \rightsquigarrow \frac{V}{(2\pi)^3} \int d^3 \underline{k} e^{-\beta\hbar^2 k^2/2m}$$

Assuming that the system is isotropic, we can transform to polar coordinates:

$$\frac{V}{(2\pi)^3} \int d^3 \underline{k} e^{-\beta\hbar^2 k^2/2m} = \frac{V}{(2\pi)^3} \int_0^\infty dk 4\pi k^2 e^{-\beta\hbar^2 k^2/2m} = \int_0^\infty dk g(k) e^{-\beta\hbar^2 k^2/2m}$$

The quantity  $g(k) = (Vk^2)/(2\pi^2)$  is known as the *density of states*, which tells us the number of microstates  $\alpha$  per  $k$  or (with appropriate substitution) per  $\varepsilon$ . From the calculation above, it is clear that the density of states depends on the dimensionality of the space; this means that the behaviour of the 3-D Ideal Gas (as described in the following sections) will be altered if we assume different dimensions for the space.

Evaluating this integral, we obtain the single particle partition function

$$\boxed{Z_1 = \frac{V}{\lambda_{th}^3} \quad \text{for} \quad \lambda_{th} = \hbar \sqrt{\frac{2\pi}{mk_B T}}} \quad (3.25)$$

It is clear that  $\lambda_{th}$  has dimensions of length in order to allow  $Z_1$  to remain dimensionless. This means that this expression *must* hold in the relativistic case, except with a different definition of  $\lambda_{th}$  (it is left as an exercise to the reader to find out exactly the definition is modified).

#### 3.4.1 Distinguishability

If we were to assume that the particles were distinguishable, we could use (3.12) to calculate the partition function for the entire system. However, if we were to calculate the entropy, we would find that it is not additive, even though it has to be additive by definition. This is a result of the fact that we have determinate momenta for the particles, but indeterminate position; this essentially means that every particle is everywhere, and so we

cannot distinguish between them. The way to get around this is by letting the occupation numbers  $n_k$  of each state  $\varepsilon_k$  take the values 0 or 1. This means that we can write the  $N$  particle partition function as

$$\boxed{Z = \frac{Z_1^N}{N!}} \quad (3.26)$$

This assumption will only hold if we assume that the number of single particle states is very much greater than  $N$ , as otherwise there will be a non-negligible probability that any particular state is occupied by more than one particle. But how much greater? The number of single particle states can be roughly approximated by the single particle partition function, as only the dominant terms remain in the sum. This means that our condition for this assumption to be valid is

$$\frac{V}{\lambda_{th}^3} \gg N \longrightarrow \frac{n}{n_Q} \ll 1$$

where we have introduced the *quantum concentration*  $n_Q = 1/\lambda_{th}^3$ . It is very easy to show quantitatively that at room temperatures that this condition is indeed satisfied.

### 3.4.2 Thermodynamic Quantities

Now that we have calculated the partition function, it is a simple matter of taking derivatives to find thermodynamic quantities of the gas. First, the Helmholtz Free Energy:

$$F = -k_B T \log(Z) = -Nk_B T \left[ 1 - \log \left( \frac{n}{n_Q} \right) \right]$$

where we have used Stirling's Formula. This means that the entropy is given by

$$\boxed{S = - \left( \frac{\partial F}{\partial T} \right)_V = k_B N \left[ \frac{5}{2} - \log \left( \frac{n}{n_Q} \right) \right]} \quad (3.27)$$

This is known as the *Sackur-Tetrode equation*. Interestingly, this is the first time that we have obtained an explicit expression for the entropy of a system; up until this point, we have simply been calculating entropy changes. We can also use this equation to find the adiabatic equations (see (3.41)) for an ideal gas by recalling that  $\Delta S = 0$  in an adiabatic process. Next, the heat capacity:

$$U = F + TS = \frac{3}{2} Nk_B T \longrightarrow C_V = \frac{3}{2} Nk_B$$

Thankfully, this is the same expression that we have derived via both Thermodynamics and Kinetic Theory. Lastly, the pressure:

$$p = - \left( \frac{\partial F}{\partial V} \right)_T = nk_B T$$

This is also the familiar result. The dependence of  $F$  on the volume comes from the dependence  $Z \propto V^N$ , and so the equation of state only depends on the factor of volume in the partition function. This in fact means that both non-relativistic and relativistic gases obey the same equation of state.

### 3.4.3 Internal Degrees of Freedom

Thus far, we have only taken into account the translational degree of freedom for the ideal gas, as we have implicitly assumed that it is monatomic gas. We can now extend our theory to diatomic gases, and consider the new degrees of freedom that this brings. If we model a diatomic molecule as two hard spheres connected by a weak spring that are free to rotate around their centre of mass, then evidently we also have vibrational and rotational degrees of freedom. This means that we can write the entire partition function as

$$Z = Z_{\text{trans.}} Z_{\text{vib.}} Z_{\text{rot.}} \quad (3.28)$$

Of course, we already have an expression for  $Z_{\text{trans.}}$ . We now simply have to find expressions for the remaining two terms.

#### Vibrational Freedom

This case is particularly simple; we can just model the molecule as a 1-D harmonic oscillator. Using (3.14), it is easy to show that

$$Z_{\text{vib.}} = \frac{e^{-\frac{1}{2}\Theta_{\text{vib.}}/T}}{1 - e^{-\Theta_{\text{vib.}}/T}} \quad (3.29)$$

where we have defined the *vibrational temperature*  $\Theta_{\text{vib.}} = \hbar\omega/k_B$ , which is the temperature at which the vibrational modes get excited. Typically, this temperature is on the order of  $T \sim 3000K$ , as so only contributes to the heat capacity at very high thermal energies.

#### Rotational Freedom

For the rotational degrees of freedom, we treat the molecule as a rigid rotor. From Quantum Mechanics (see A3 notes), it can be shown that the energy levels of such a system are given by

$$\varepsilon_\ell = \frac{\hbar^2}{2I}\ell(\ell + 1)$$

for  $I = \mu r_0^2$ , where  $\mu$  is the reduced mass, and  $r_0$  is the average distance between the atomic centres. The degeneracy of each energy level is  $(2\ell + 1)$ . This means that the partition function becomes

$$Z_{\text{rot.}} = \sum_{\ell=0}^{\infty} (2\ell + 1)e^{-\beta\varepsilon_\ell} = \sum_{\ell=0}^{\infty} (2\ell + 1)e^{-\ell(\ell+1)\Theta_{\text{rot.}}/T}$$

where we have introduced the *rotational temperature*  $\Theta_{\text{rot.}} = \hbar^2/(2Ik_B)$ . This is typically on the order of  $\sim 10K$ , meaning that for most scenarios, we can approximate the sum as an integral. Performing the integration, by noting that  $d\ell(2\ell + 1) = d(\ell(\ell + 1))$ , we find that

$$Z_{\text{rot.}} = \frac{T}{2\Theta_{\text{rot.}}} \quad (3.30)$$

This result proves very accurate, except for at lower temperatures. In the lower temperature limit, it is clear that the contribution to the heat capacity is approximately zero; the partition function is dominated by the large Boltzmann factor, and so effectively tends to zero. To find a more accurate approximation around this limit, one can take the  $\ell = 0$  and  $\ell = 1$  terms, and calculate the contribution to the heat capacity from there.

### Total Heat Capacity

As we calculate the Helmholtz Free Energy by taking the log of the partition function, it is simply the sum of the separate Helmholtz Free energies for each degree of freedom. Due to the linearity of differentiation, this means that the total heat capacity is simply the sum of the heat capacities that result from the translational, and rotational modes, with the latter two adding  $Nk_B$  to the total. Evidently, which modes are excited depends on temperature, and so the resultant heat capacity takes the form:

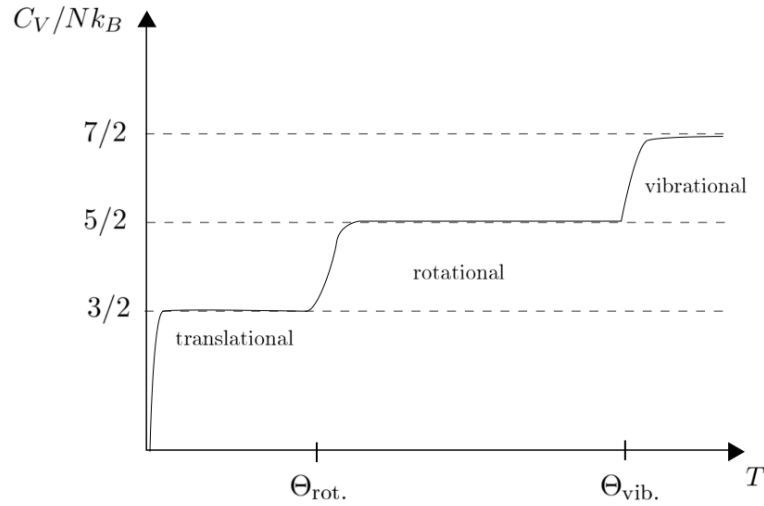

Figure 3.1: The variation of the heat capacity of a diatomic gas with temperature

#### 3.4.4 The Equipartition Theorem

The *Equipartition Theorem* states that

*If the energy of a classical system is the sum of  $q$  quadratic modes, and the system is in contact with a heat reservoir at temperature  $T$ , then the mean energy of the system is given by  $U = \frac{1}{2}qk_B T$ .*

Assume that the energy of the system is given by the sum of quadratic modes

$$E = \sum_{i=1}^q \alpha_i x_i^2$$

Assuming the probabilities to be Gibbsian, the mean energy can be calculated as follows:

$$\begin{aligned} U &= \frac{\int \dots \int dx_1 \dots dx_n \left( \sum_{i=1}^q \alpha_i x_i^2 \right) \exp \left( -\beta \sum_{i=1}^q \alpha_i x_i^2 \right)}{\int \dots \int dx_1 \dots dx_n \exp \left( -\beta \sum_{j=1}^q \alpha_j x_j^2 \right)} \\ &= \sum_{i=1}^q \frac{\int_{-\infty}^{\infty} dx_i \alpha_i x_i^2 \exp(-\beta \alpha_i x_i^2)}{\int_{-\infty}^{\infty} dx_i \exp(-\beta \alpha_i x_i^2)} \\ &= \sum_{i=1}^q \alpha_i \langle x_i^2 \rangle \\ &= \frac{1}{2} q k_B T \end{aligned}$$

Note that this is only valid at high temperatures. However, this does mean that any results we derive using more complicated theories must reduce to the results predicted by

equipartition in the high temperature limit.

One particular application of the equipartition theorem is in the prediction of the heat capacity of gases. It follows directly from the equipartition theorem that for ideal gases with a number of degrees of freedom  $f$ :

$$C_V = \frac{f}{2}R \quad \text{and} \quad C_p = \left(\frac{f}{2} + 1\right)R \quad (3.31)$$

Evidently, the value of  $f$  will depend on whether the translational (3), rotational (2) or vibrational (2) modes are excited, as we saw in the previous section.

### 3.4.5 With the Grand Canonical Ensemble

Suppose that for each microstate  $\alpha$  we now have possible occupation numbers  $\alpha_N = \{n_{k_1}, n_{k_2}, \dots\}$  such that  $\sum_k n_k = N$ . The grand partition function is therefore:

$$\mathcal{Z} = \sum_N \sum_{\alpha_N} e^{\beta\mu N} e^{-\beta E_{\alpha_N}} = \sum_N e^{\beta\mu N} \frac{1}{N!} \left(\frac{V}{\lambda_{th}^3}\right)^N = \sum_N \frac{1}{N!} \left(Z_1 e^{\beta\mu}\right)^N$$

Recognising that this is the series definition of the exponential, we arrive at

$$\boxed{\mathcal{Z} = e^{Z_1 e^{\beta\mu}}} \quad (3.32)$$

where  $Z_1$  is the single-particle canonical partition function. Note that all the results for an ideal gas with fixed  $N$  are still valid under this ensemble, except now we replace  $N$  by  $\bar{N}$ . However, now we can find the chemical potential of an ideal gas. This is most easily done as the solution to an equation for  $\bar{N}$ .

$$\Phi = -k_B T \log(\mathcal{Z}) = -k_B T Z_1 e^{\beta\mu}$$

Then, the mean particle number is given by (3.22)

$$\bar{N} = Z_1 e^{\beta\mu} \longrightarrow \mu = -k_B T \log\left(\frac{Z_1}{\bar{N}}\right)$$

However, recall that  $Z_1 = Z_1^{\text{trans.}} Z_1^{\text{internal}}$ . This means that we can write the chemical potential in the useful form

$$\boxed{\mu = k_B T \log\left(\frac{n \lambda_{th}^3}{Z_1^{\text{internal}}}\right)} \quad (3.33)$$

As a sanity check, let us examine whether  $\mu$  is large and negative (as it should be in the classical limit). By definition, we require that  $Z_1^{\text{internal}} \geq 1$ , and we know that  $n \lambda_{th}^3 \ll 1$  in this limit. This means that it is indeed large and negative.

*Consider a volume  $V$  of classical ideal gas with mean number density  $n = \bar{N}/V$ , where  $\bar{N}$  is the mean number of particles in this volume. Starting from the grand canonical distribution, show that the probability to find exactly  $N$  particles in this volume is a Poisson distribution.*

We are considering a particular set of microstates of the system for which the particle number is  $N$ . Letting  $\alpha = \alpha_N$  such that  $N_\alpha = N$ :

$$p_N = \frac{e^{\beta\mu N}}{\mathcal{Z}} \underbrace{\sum_N e^{-\beta E_{\alpha_N}}}_{\text{sum of energies in } N} = \frac{e^{\beta\mu N}}{\mathcal{Z}} Z_N = \frac{e^{\beta\mu N}}{\mathcal{Z}} \frac{Z_1^N}{N!}$$

It follows directly from (3.33) that the grand partition function can be written in the form  $\mathcal{Z} = e^{\bar{N}}$ . Then:

$$p_N = \frac{Z_1^N}{N!} e^{-\bar{N}} e^{\beta N \left[ \frac{1}{\beta} \log \left( \frac{\bar{N}}{Z_1} \right) \right]} = \frac{Z_1^N}{N!} e^{-\bar{N}} e^{\log \left[ \left( \frac{\bar{N}}{Z_1} \right)^N \right]} = \frac{\bar{N}^N e^{-\bar{N}}}{N!}$$

which is indeed a Poisson distribution with mean  $\bar{N}$ . This result can also be proven by considering a limiting case of a Binomial distribution for particles being in a volume  $V$ .

### Equilibria of Inhomogeneous Systems

Thus far, we have considered the entire system of the ideal gas to be homogeneous. Now, let us introduce some potential per particle  $\phi(\underline{r})$  into the system, and ask how this changes the equilibrium state of the system. We are going to make use of the fact that in equilibrium, the only parameter that is allowed to vary in space is  $n$ ; we showed that the other parameters must be fixed in Section (3.2.2).

Suppose that our potential  $\phi(\underline{r})$  behaves in a way such that  $\phi(0) = 0$ , and results in some energy shift  $\varepsilon_\phi$  for the system. This means that we can write the partition function as

$$Z_1 = Z_1(0) Z_1^\phi = Z_1(0) e^{-\beta \varepsilon_\phi}$$

where  $Z_1(0)$  is the partition function of the system in the absence of the potential. Then, we can write the chemical potential as

$$\mu = -k_B T \log \left( \frac{Z_1(0) e^{-\beta \varepsilon_\phi}}{\bar{N}} \right) = k_B T \log \left( \frac{n \lambda_{th}^3}{Z_1^{\text{internal}}} \right) + \varepsilon_\phi$$

By definition,  $\mu$  and  $T$  must be constant in equilibrium, and so the only parameter that is allowed to vary is  $n$ , as stated above. We can thus arbitrarily set  $\mu = 0$ , as we are only looking at changes in the system, meaning that:

$$\log \left( \frac{n \lambda_{th}^3}{Z_1^{\text{internal}}} \right) = -\frac{\varepsilon_\phi}{k_B T}$$

So that in general the density distribution is given by

$$\boxed{n(\underline{r}) = n(0) e^{-\beta \varepsilon_\phi}} \quad (3.34)$$

*An ideal gas is placed inside a cylinder of radius  $R$  and height  $h$  that is rotating at angular frequency  $\Omega$ . Find the density distribution of the gas in equilibrium.*

The number density profile of a gas should not change under frame transformation, meaning that we can arbitrarily transform to the rotating frame of the gas. In this frame, the particles will be subject to a "centrifugal potential" given by

$$\phi(\underline{r}) = -\frac{1}{2}(\Omega r)^2 \quad \longrightarrow \quad \varepsilon_\phi = -\frac{1}{2}m(\Omega r)^2$$

Using (3.34):

$$n(\underline{r}) = n(0) e^{Ar^2}$$

for  $A = 1/2\beta m\Omega^2$ . Now, we have to find our normalisation constant  $n(0)$ . Evidently, we require that the total number of particles is equal to the number density integrated over the volume of the cylinder. Thus:

$$N \stackrel{!}{=} \int dV n(\underline{r}) = 2\pi h n(0) \int dr r e^{Ar^2} = 2\pi h n(0) \frac{e^{AR^2} - 1}{2A}$$

Re-arranging, we can write that

$$n(r) = \bar{n} \frac{AR^2 e^{Ar^2}}{e^{AR^2} - 1}$$

for  $\bar{n} = N/(\pi R^2 h)$ . We can now look at some limits to ascertain whether our expression makes any sense. To make things easier, consider the value of  $n$  at  $r = R$ .

- High temperature limit ( $T \rightarrow \infty$ ) - In this limit,  $\beta$  becomes very small. This means that we can Taylor expand the exponential factor in  $A$ :

$$n(R) \sim \bar{n} \frac{AR^2}{1 + AR^2 - 1} = \bar{n}$$

This makes sense, as at very high temperatures, the thermal energy will be so high that the gas does not care about the effects of the rotation

- Low temperature limit ( $T \rightarrow 0$ ) - In this limit,  $\beta$  becomes very large, and so the exponential factor will dominate.

$$n(R) \sim \bar{n} AR^2 = \frac{1}{2} \frac{m\bar{n}(\Omega R)^2}{k_B T}$$

This is a large factor due to  $T$  being small. This we would also expect as the molecules would be dominated by the effect of the rotation, and would cluster in a small cylindrical shell around the rim of the cylinder.

### 3.5 Quantum Gases

Before jumping into the very interesting world of quantum gases, we first have to look at a particularly important property of the sorts of particles that we will be considering. Let  $|1, 2\rangle$  be the ket representing the state of two particles; the first particle on the left (in state 1) and the second particle on the right (in state 2). Let us now 'swap' the two particles. Assuming that they are indistinguishable, this should not change the modulus of the state vector:

$$\begin{aligned} ||1, 2\rangle|^2 &= ||2, 1\rangle|^2 \\ |2, 1\rangle &= e^{i\phi} |1, 2\rangle \end{aligned}$$

If we now swap the particles in the second ket, we obtain

$$|2, 1\rangle = \underbrace{e^{2i\phi}}_{e^{i\phi}=\pm 1} |2, 1\rangle$$

This means that there are two possible *exchange symmetries*:

1.  $|1, 2\rangle = |2, 1\rangle$  for bosons that have integer spin
2.  $|1, 2\rangle = -|2, 1\rangle$  for fermions that have half integer spin

Suppose now that the states "1" and "2" are in fact the same state. This means that for fermions  $|1, 1\rangle = -|1, 1\rangle = 0$ ; that is, *no two fermions can occupy the same quantum state*. This is known, quite famously, as the *Pauli Exclusion Principle*.

This actually has an important effect on the behaviour of quantum gases. Unlike with the states of real gases, those of quantum gases are collective states; the system appears to "know" about what the rest of the system is doing. As such, the *occupation numbers* (the amount in said state) of particular energy states are bounded for fermions ( $n_i = 0, 1$ ) by the Pauli Exclusion Principle, but in principle unbounded for bosons ( $n_i = 0, 1, \dots, N$ ). This crucial difference between Fermi and Bose gases leads to quite different behaviours under certain conditions, as we will soon see.

#### 3.5.1 Occupation Number Statistics

Consider a the set of occupation numbers  $\{n_i\}$  that correspond to the set of energy states  $\{i\}$ . Let  $\varepsilon_i$  be the single particle energy levels. This means that we can write the Grand Partition Function as

$$\mathcal{Z} = \sum_{\{n_i\}} e^{-\beta \sum_i n_i (\varepsilon_i - \mu)} = \sum_{\{n_i\}} \prod_i e^{-\beta n_i (\varepsilon_i - \mu)} = \prod_i \sum_{\{n_i\}} \left[ e^{-\beta (\varepsilon_i - \mu)} \right]^{n_i}$$

Now for fermions,  $n_i$  can take the values 0 and 1, and so the partition function simplifies to

$$\mathcal{Z}_{\text{fermions}} = \prod_i \left( 1 + e^{-\beta (\varepsilon_i - \mu)} \right)$$

For bosons,  $\bar{n}_i$  is unbounded, meaning that we obtain an infinite geometric series that we can sum to

$$\mathcal{Z}_{\text{bosons}} = \prod_i \frac{1}{1 - e^{-\beta (\varepsilon_i - \mu)}}$$

Taking the logarithm of the partition functions (which, after all, is what we usually want), we find the surprisingly simple expression

$$\boxed{\log \mathcal{Z} = \pm \sum_i \log \left( 1 \pm e^{-\beta(\varepsilon_i - \mu)} \right)} \quad (3.35)$$

where the "+" sign corresponds to fermions, and the "-" sign corresponds to bosons. This will remain the case throughout the remainder of this section unless otherwise stated.

Let us now go back to considering our microstates  $\{\alpha\}$ . The probability to be in a particular microstate  $\alpha$  will be a function of the occupation numbers  $\{n_i\}$ , as these will determine the amount of particles in each of the energy levels, and thus the energy of the particular state. Let us calculate the *mean occupation numbers* for each of these states. Using the definition of  $p_\alpha$  in the Grand Canonical Ensemble:

$$\begin{aligned} \bar{n}_i &= \sum_{\{n_j\}} n_i p(n_1, n_2, \dots, n_j, \dots) \\ &= -\frac{1}{\mathcal{Z}} \frac{1}{\beta} \frac{\partial}{\partial \varepsilon_i} \sum_{\{n_j\}} e^{-\beta \sum_j n_j (\varepsilon_j - \mu)} \\ &= -\frac{1}{\beta} \frac{\partial}{\partial \varepsilon_i} \log \mathcal{Z} \end{aligned}$$

Substituting in (3.35), we arrive at the very important results for the mean occupation numbers of

$$\boxed{\bar{n}_i = \frac{1}{e^{\beta(\varepsilon_i - \mu)} \pm 1}} \quad (3.36)$$

where "+" corresponds to Fermi-Dirac statistics (fermions), and "-" corresponding to Bose-Einstein statistics (bosons). If you are going to memorize any result in the Statistical Mechanics of quantum gases, it would be this one, as it allows you go calculate everything else.

### 3.5.2 Density of States

Now that we have the mean occupation numbers for each of the energy levels, we can start calculating various quantities, such as

$$N = \sum_i \bar{n}_i \quad \text{or} \quad U = \sum_i \bar{n}_i \varepsilon_i$$

As we known, sums tend to be hard to evaluate, while integrals are typically much easier. As we saw in Section (3.4), we can turn these sums into integrals.

$$\sum_i = \underbrace{(2s+1)}_{\text{spin components}} \sum_{\underline{k}} = (2s+1) \underbrace{\frac{V}{(2\pi)^3}}_{\text{from mesh size}} \int d^3k = \underbrace{\frac{(2s+1)V}{2\pi^2} \int_0^\infty dk k^2}_{\text{moving to polar coordinates}}$$

This means that the *density of states* is

$$g(k) = \frac{(2s+1)V}{2\pi^2} k^2$$

This is essentially the same as we found before, except we are now taking into account the spin of the particles, which is an intrinsically quantum mechanical effect.

Now, how we calculate the density of states, as before, depends on the regime in which we are working, as this will determine the corresponding relationship between  $k$  and  $\varepsilon$ .

- Non-relativistic limit ( $k_B T \ll mc^2$ ) - In this case, the energy relation is clearly

$$\varepsilon = \frac{p^2}{2m} = \frac{\hbar^2 k^2}{2m} \rightarrow dk = \frac{\sqrt{2m}}{\hbar} \frac{1}{2\sqrt{\varepsilon}} d\varepsilon$$

Recalling that  $g(k) dk = g(\varepsilon) d\varepsilon$ , we find that the density of states is clearly

$$g(\varepsilon) = \frac{(2s+1)Vm^{3/2}}{\sqrt{2\pi^2\hbar^3}} \sqrt{\varepsilon} \quad (3.37)$$

- Ultra-Relativistic Limit ( $k_B T \gg mc^2$ ) - We know that the energy for a relativistic particle is  $\varepsilon = \sqrt{m^2c^4 + \hbar^2k^2c^2}$ . In the ultra-relativistic case,  $\varepsilon \sim \hbar kc$ . Through a similar calculation, the density of states can be obtained as

$$g(\varepsilon) = \frac{(2s+1)V}{2\pi^2(\hbar c)^3} \varepsilon^2 \quad (3.38)$$

Numerical constants aside, we can see that the energy component of these states differs by a factor of  $\varepsilon^{3/2}$ , which means that we will observe different sorts of behaviour for Quantum Gases that are in the non-relativistic and ultra-relativistic limits. The reason why we usually work in one of these two limits is that the calculations using the exact form of the energy become horrendously complicated, and thus is not worth considering; we can extrapolate backwards from these two limits to determine the behaviour in the exact case.

### 3.5.3 Standard Calculations

This section will simply cover some of the standard calculations that students need to be familiar with when it comes to quantum gases. Everything will remain in complete generality, so the results derived will be valid for both fermion and boson gases, though using the density of states expression (3.37), but results will be included for both cases where convenient.

#### Chemical Potential

Let us begin by calculating the chemical potential. We will have to do this implicitly; that is, we will have to determine  $\mu$  as the analytic solution to some equation for  $N(\mu, T)$ .

$$N = \sum_i \bar{n}_i = \int_0^\infty d\varepsilon \frac{g(\varepsilon)}{e^{\beta(\varepsilon-\mu)} \pm 1} = \frac{(2s+1)V}{\lambda_{th}^3} \int_0^\infty d\varepsilon \frac{2}{\sqrt{\pi}} \frac{\sqrt{\varepsilon} \beta^{3/2}}{e^{\beta(\varepsilon-\mu)} \pm 1}$$

Making the substitution  $x = \beta\varepsilon$ :

$$n = \underbrace{\frac{(2s+1)}{\lambda_{th}^3}}_{\text{quantum concentration, } n_Q} \underbrace{\frac{2}{\sqrt{\pi}} \int_0^\infty dx \frac{\sqrt{x}}{e^{x-\beta\mu} \pm 1}}_{f(\beta, \mu)}$$

This reduced to the quite simple expression

$$\frac{n}{n_Q} = f(\beta, \mu) \quad (3.39)$$

A similar one can be obtained for the relativistic gas, except that  $n_Q$  and  $f(\beta, \mu)$  will have different definitions (watch out for this when doing calculations!). We can obtain a solution to this equation for  $\mu$  for given values of  $T$  and  $n$ .

## Mean Energy

Again, we are going to have to convert our sum into an integral.

$$U = \sum_i \bar{n}_i \varepsilon_i = \int_0^\infty d\varepsilon g(\varepsilon) \frac{\varepsilon}{e^{\beta(\varepsilon-\mu)} \pm 1} = Nk_B T \left( \frac{n_Q}{n} \frac{2}{\sqrt{\pi}} \int_0^\infty dx \frac{x^{3/2}}{e^{x-\beta\mu} \pm 1} \right)$$

This equation does not have any particular meaning at this stage. However, when it is written in this form, we can see that we require the quantity in brackets to reduce to  $3/2$  in the classical limit, that we will examine in Section (3.5.3).

## The Grand Potential

Let us now calculate the Grand Potential, as this will allow us to find the equation of state.

$$\begin{aligned} \Phi &= -k_B T \log \mathcal{Z} = \mp k_B T \int_0^\infty d\varepsilon g(\varepsilon) \log \left( 1 \pm e^{-\beta(\varepsilon-\mu)} \right) \\ &= \mp Nk_B T \frac{n_Q}{n} \frac{2}{\sqrt{\pi}} \int_0^\infty dx \underbrace{\sqrt{x}}_{=\frac{2}{3} \frac{d}{dx}(x^{3/2})} \log \left( 1 \pm e^{-\beta(\varepsilon-\mu)} \right) \end{aligned}$$

Integrating by parts:

$$\Phi = -\frac{2}{3} Nk_B T \left( \frac{n_Q}{n} \frac{2}{\sqrt{\pi}} \int_0^\infty dx \frac{x^{3/2}}{e^{x-\beta\mu} \pm 1} \right) = -\frac{2}{3} U$$

from above. This means that we can use (3.19) to find the equation of state as

$$p = \xi \frac{U}{V} \quad \text{where} \quad \xi = \begin{cases} \frac{2}{3} & \text{for non-relativistic} \\ \frac{1}{3} & \text{for relativistic} \end{cases} \quad (3.40)$$

Note these equations of state are valid regardless of whether the gas is in the classical limit, degenerate limit or in between, as the derivation has been done without evaluating any of the expressions. We are starting to see that the differences in the density of states between non-relativistic and ultra-relativistic gases leads to a difference in coefficients in the common expressions.

## Entropy

Using the results of Section (3.5.3), it follows that

$$S = \frac{U - \Phi - \mu N}{T} = \frac{(1 + \xi)U - \mu N}{T}$$

where  $\xi$  has the definition as above. Now consider an adiabatic process; we know that in such a process that both  $S$  and  $N$  must remain constant. This means that

$$\frac{S}{N} = \underbrace{(1 + \xi) \frac{U}{NT}}_{\text{only depends on } \beta\mu} - \frac{\mu}{T} = \text{function of } \frac{\mu}{T} \text{ only}$$

meaning that as the left-hand side of the above equation is constant,  $\mu/T$  must also be a constant in an adiabatic process. This means that

$$\frac{n}{n_Q} = \text{constant}$$

for the appropriate definition of  $n_Q$ . Using (3.40), we arrive at the result of

$$pV^{1+\xi} = \text{constant} \quad (3.41)$$

### Classical Limit

The Correspondence Principle tells us that any results we derive in a quantum mechanical system must hold in the classical limit. We now ask the question *what is the classical limit for quantum gases?* In general, the classical limit will occur where the gas is hot ( $T \rightarrow \infty$ ) and dilute ( $n \rightarrow 0$ ). In this limit,  $e^{-\beta\mu} \gg 1$ . Then:

$$f(\beta, \mu) = \frac{2}{\sqrt{\pi}} \int_0^\infty dx \frac{\sqrt{x}}{e^{x-\beta\mu} \pm 1} \sim \frac{2}{\sqrt{\pi}} \int_0^\infty dx \sqrt{x} e^{-x} e^{\beta\mu} = e^{\beta\mu}$$

Using the definition of  $f(\beta, \mu)$ , this means that the condition for the classical limit of a quantum gas is

$$\boxed{\frac{n}{n_Q} \ll 1} \quad (3.42)$$

again for appropriate definitions of  $n_Q$ . This is in fact the same condition that we found in Section (3.4.1). This result can be used to show that the mean occupation numbers  $\bar{n}_i$  for Fermi-Dirac and Bose-Einstein statistics reduce to a Maxwellian concentration in the classical limit.

### Degeneration

In this context, *degeneration* occurs when the number of quantum states available to a single particle becomes comparable to the number of particles in the system. Physically, we can interpret our quantum concentration  $n_Q$  as 'concentration' of quantum states for the system, coming from the density of states. This means that we would expect degeneration appear when  $n$  is on the order of  $n_Q$ , namely that

$$\frac{n}{n_Q} \gtrsim 1$$

By writing  $n_Q$  explicitly and  $n$  in terms of the pressure  $p$ , we can show that air at STP is safely non-degenerate ( $n/n_Q \sim 10^{-6}$ ), where as electrons in metals are very much degenerate ( $n/n_Q \sim 10^4$ ) under everyday conditions. This means that we cannot describe the properties of electrons in metals via classical models; we require Fermi-Dirac statistics in the degenerate limit. The following two sections will examine how Fermi and Bose gases behave when they become degenerate.

#### 3.5.4 Degenerate Fermi Gas

Consider a Fermi gas for which  $T \rightarrow 0$  so  $\beta \rightarrow \infty$ . Then, considering carefully the behaviour of the exponential factor, the mean occupation numbers will behave according to

$$\bar{n}_i = \frac{1}{e^{\beta(\varepsilon_i - \mu)} + 1} \rightarrow \begin{cases} 1 & \text{for } \varepsilon_i < \mu(T=0) \\ 0 & \text{for } \varepsilon_i > \mu(T=0) \end{cases}$$

This is shown in Figure (3.2). The consequence of this is that when Fermi gases become degenerate, the electrons will begin to 'stack up' and occupy all the available single-particle states from the lowest-energy one to maximum energy equal to the value of the chemical potential at  $T = 0$

$$\varepsilon_F = \mu(T = 0)$$

This quantity  $\varepsilon_F$  is known as the *Fermi energy*, and tells us what the maximum energy per particle is at  $T = 0$ . Let us find an expression for the Fermi energy, remembering that in this state the occupation number has become a step-function.

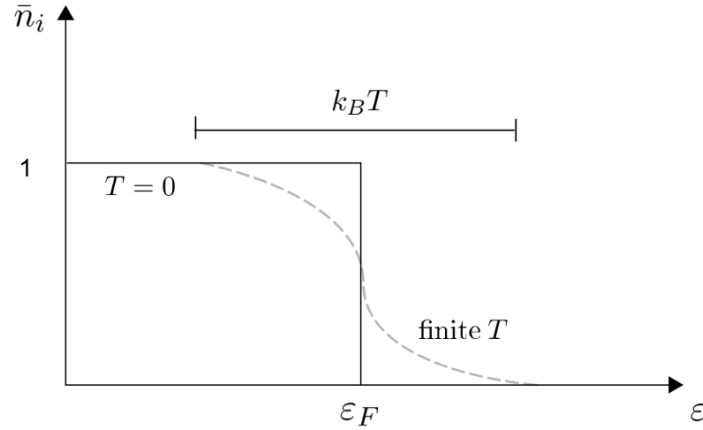

Figure 3.2: The occupation numbers for  $T = 0$  and some finite correction

As the Fermi energy is merely the chemical potential at  $T = 0$ , we use the same method as we usually use to calculate the chemical potential.

$$N = \underbrace{\int_0^{\epsilon_F} d\epsilon g(\epsilon)}_{\text{as step function}} = n_Q V \beta^{3/2} \frac{2}{\sqrt{\pi}} \int_0^{\epsilon_F} d\epsilon \sqrt{\epsilon} = n_Q V \beta^{3/2} \frac{2}{\sqrt{\pi}} \left( \frac{2}{3} \epsilon_F^{3/2} \right)$$

Rearranging, we find that the Fermi energy is given by

$$\boxed{\epsilon_F = \left( \frac{6\pi^2 n}{2s+1} \right)^{2/3} \frac{\hbar^2}{2m}} \quad (3.43)$$

This actually allows us to find a criterion for treating Fermi gases as quantum gases at zero temperature. Looking at Figure (3.2), it is clear that this is limited by the width of the curve,  $k_B T$ , and so this treatment is valid for temperatures satisfying

$$T \ll T_F = \frac{\epsilon_F}{k_B} \sim \frac{\hbar^2 n^{2/3}}{mk_B}$$

where  $T_F$  is known as the *Fermi temperature*. This can be interpreted as roughly the temperature at which the gas becomes degenerate.

### Sommerfeld Expansion

It is very easy to show (have a go yourself!) that to first order the mean energy for a Fermi gas is given by

$$U \propto N \epsilon_F$$

However, this poses a problem for calculating further quantities, such as the heat capacity, as this expression is independent of temperature. This does make sense; at absolute zero, it would require a vanishingly small amount of energy to increase the temperature of the system. We thus need to find another way of evaluating our integrals for finite  $T \sim 0$ ; that is, to take into account the curve shown in Figure (3.2).

It can be shown that integrals of the form

$$I = \int_0^\infty d\epsilon \frac{f(\epsilon)}{e^{\beta(\epsilon-\mu)} + 1}$$

where  $f(\varepsilon)$  is an arbitrary function, can be expanded around  $T = 0$  as

$$I \sim \int_0^\mu d\varepsilon f(\varepsilon) + \frac{\pi^2}{6} f'(\mu) (k_B T)^2 + \dots \quad (3.44)$$

This expansion proves to be quite accurate, as it is already to second order. This a result that is worth remembering for Fermi gases, as it allows us to calculate quantities to greater precision.

### Thermodynamic Quantities

Let us now use the Sommerfeld to calculate some of the thermodynamic quantities of a degenerate Fermi gas. It is a useful exercise to check that the results match those predicted by first order theory. The density of stats can be written as

$$g(\varepsilon) = \frac{N}{(2/3)\varepsilon_F^{3/2}} \sqrt{\varepsilon}$$

This is useful as we are interested in how these quantities scale relative to  $\varepsilon_F$ . Let us begin by calculating the chemical potential from  $N$ :

$$N = \frac{N}{(2/3)\varepsilon_F^{3/2}} \left[ \frac{2}{3} \mu^{3/2} + \frac{\pi^2}{6} \frac{1}{2\sqrt{\mu}} (k_B T)^2 + \dots \right]$$

Observing that  $\mu \sim \varepsilon_F + \dots$ , we can re-arrange this expression to obtain the equation

$$\mu = \varepsilon_F \left[ 1 - \frac{\pi^2}{12} \left( \frac{k_B T}{\varepsilon_F} \right)^2 + \dots \right] \quad (3.45)$$

Evidently, this expression is well-behaved; it reduces to  $\mu = \varepsilon_F$  at  $T = 0$ , which it has to by the definition of  $\varepsilon_F$ . This is plotted in the figure below. We see that it becomes very large and negative at high temperatures, as anticipated by (3.33).

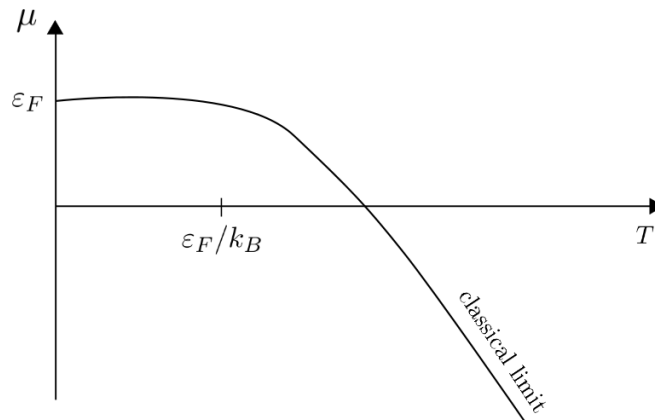

Figure 3.3: The chemical potential of a degenerate Fermi gas

The next step is to consider the mean energy  $U$  with the aim of finding the chemical potential.

$$U = \frac{N}{(2/3)\varepsilon_F^{3/2}} \left[ \frac{2}{5} \mu^{5/2} + \frac{\pi^2}{6} \frac{3}{2} \sqrt{\mu} (k_B T)^2 + \dots \right] = \frac{3}{5} N \varepsilon_F \left[ 1 + \frac{5\pi^2}{12} \left( \frac{k_B T}{\varepsilon_F} \right)^2 + \dots \right]$$

where we have again used that  $\mu \sim \varepsilon_F + \dots$ , and (3.45). It then follows from the definition of heat capacity that

$$C_V = \frac{\pi^2}{2} N k_B \frac{k_B T}{\varepsilon_F} \quad (3.46)$$

Thus, the correction to our zero-temperature result is initially linear in  $T$  for  $T \lesssim \varepsilon_F/k_B$ , as can be seen in the figure below.

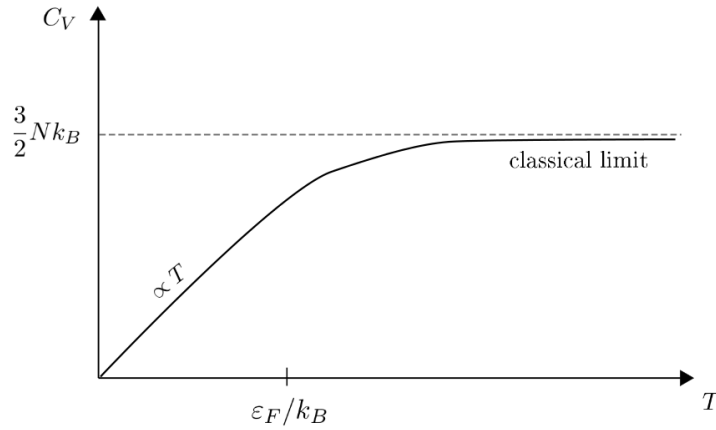

Figure 3.4: The heat capacity of a degenerate Fermi gas

We could also have anticipated this result qualitatively. As we increase the temperature above  $T = 0$ , we get some excited particles. For small corrections, the number of excited particles  $\Delta N_{\text{exc.}}$  is given roughly by

$$\Delta N_{\text{exc.}} \sim g(\varepsilon_F) \Delta \varepsilon$$

Looking at Figure (3.2), we can see that  $\Delta \varepsilon \sim k_B T$ . This means that the change in the energy of the system scales roughly as

$$\Delta U \sim \Delta N_{\text{exc.}} \Delta \varepsilon \sim g(\varepsilon_F) (k_B T)^2 \sim \frac{N}{\varepsilon_F} (k_B T)^2$$

We thus obtain the same dependence for  $C_V$  upon differentiation, where we have simply considered the width of the distribution around  $T = 0$ ; this is more of 'hand-wavey' way of deriving the dependence.

All that remains is to calculate the equation of state. We can simply use (3.40) and our expression for  $U$  from above.

$$p = \xi \frac{U}{V} = \xi \frac{3}{5} n \varepsilon_F \left[ 1 + \frac{5\pi^2}{12} \left( \frac{k_B T}{\varepsilon_F} \right)^2 + \dots \right] \quad (3.47)$$

We observe, interestingly, that the pressure of a degenerate Fermi gas is actually non-zero at  $T = 0$ , and at this point it is proportional to  $n^{5/3}$  (from the definition of  $\varepsilon_F$ ).

*Derive the Chandrasekhar mass limit for white dwarfs. Consider the star to be a relativistic degenerate Fermi gas, and find the stable mass by extremising the total energy (gravitational and from the electrons).*

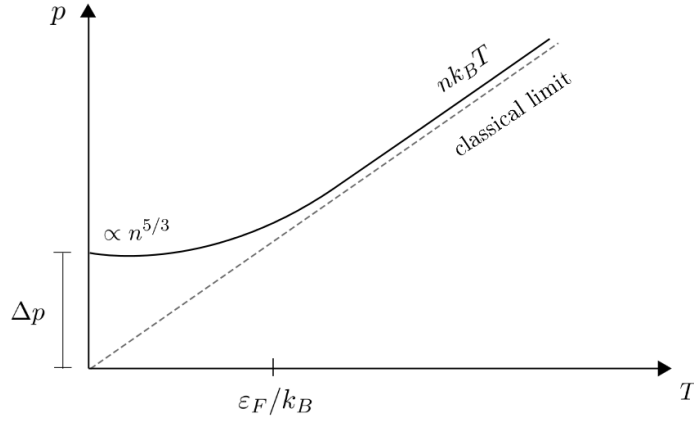

Figure 3.5: The pressure of a degenerate Fermi gas

The immediate question that we need to ask ourselves is as to why we can neglect the energy of the protons; after all, there are equal numbers of electrons and protons for the star to be electro-statically neutral. The answer lies in degeneracy. Looking at (3.43), and recalling that  $T_F \sim T_{\text{deg}}$ , we can see that the degeneration temperature scales inversely with mass. This means that the electrons will become degenerate before the protons. But why does this matter? Looking at the figure above, it is clear that the pressure of a degenerate gas is much more than that of a non-degenerate gas, and at the density in stars, we can essentially treat the electron gas as being at  $T = 0$  as  $T_F$  is very large. This is the reason for neglecting the contribution of the protons.

Now that this is understood, we can now begin with the derivation. We are going to work on the simplifying assumption that the star has a constant density cross-section; this is of course not the case, but still allows us to obtain relatively sensible results. First, let us find the potential energy of the system by building the star out of spherical shells.

$$dU_g = -\frac{GM}{r} dM = -\frac{G}{r} \left( \frac{4}{3}\pi r^3 \rho \right) (4\pi r^2 \rho dr) = -\frac{16\pi^2}{3} G \rho^3 r^4 dr$$

Integrating:

$$U_g = -\frac{16\pi^2}{3} G \rho^2 \int_0^R dr r^4 = -\frac{16\pi^2 G \rho^2 R^5}{15 \cdot 5} = -\frac{3GM^2}{5R} = -\frac{B}{R}$$

Now for finding the energy due to the electron gas. It is easy to show that the Fermi energy for an ultra-relativistic gas is given by

$$\varepsilon_F = \hbar c \left( \frac{6\pi^2 n}{2s+1} \right)^{1/3} \longrightarrow g(\varepsilon) = \frac{N}{(1/3)\varepsilon_F^3} \varepsilon^2$$

where we have re-written the density of states(3.38). Then:

$$U_e = \frac{N}{(1/3)\varepsilon_F^3} \int_0^{\varepsilon_F} d\varepsilon \varepsilon^3 = \frac{3}{4} N \varepsilon_F = \frac{\hbar c}{4\pi^2} (3\pi^2)^{4/3} \left( \frac{4}{3}\pi \right)^{-1/3} N^{4/3} R^{-1} = \frac{A}{R}$$

where we have used the fact that  $V = (4/3)\pi R^3$ . The total energy of the system is thus

$$U_T = U_e + U_g = \frac{A}{R} - \frac{B}{R}$$

The critical point clearly occurs when  $A = B$ . Re-arranging this equality, we find the expression for the mass as

$$M = \frac{3\sqrt{\pi}}{m_p^2} \left(\frac{5}{16}\right)^{3/2} \left(\frac{\hbar c}{G}\right)^{3/2} \sim 1.7 M_\odot$$

This is actually a little larger than the actual Chandrasekhar limit, but this is due to the fact that we have approximated the density as being constant. We can do similar calculations for non-relativistic white-dwarfs, and we obtain a stable radius  $R$  that scales with  $M^{-1/3}$ . This is an interesting result, as it means that if mass is added to the star, it will shrink. It is not immediately obvious, or intuitive, that this should be the case!

### 3.5.5 Degenerate Bose Gas

We are now going to consider the behaviour of a degenerate Bose gas. We know that for such a gas, the occupation numbers are given by

$$\bar{n}_i = \frac{1}{e^{\beta(\varepsilon_i - \mu)} - 1}$$

Now, it is clear that in order to avoid negative occupation numbers (which have no physical meaning), we required that  $\mu < \varepsilon_i$ . This means that  $\mu < \varepsilon_{\min} = \varepsilon_0 = 0$ , where we have arbitrarily chosen the lowest energy state to be that of zero energy. As  $T \rightarrow 0$ , there is nothing to stop the bosons occupying the same energy state, and so the lowest energy level becomes macroscopically occupied. In this limit:

$$\bar{n}_0 = \frac{1}{e^{-\beta\mu} - 1} = N \rightarrow \mu(T \rightarrow 0) = -k_B T \log\left(1 + \frac{1}{N}\right) \sim -\frac{k_B T}{N} \sim 0$$

This means that the chemical potential for a Bose gas is vanishingly small for these low temperatures, as seen below.

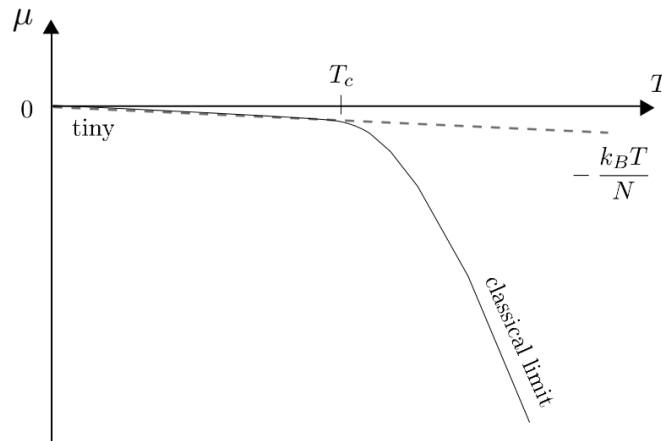

Figure 3.6: The chemical potential of a degenerate Bose gas

We know that the density of states  $g(\varepsilon) \propto \varepsilon^p$  for some power  $p$  (not necessarily an integer). This means that the particles in the lowest energy states  $\varepsilon_0 = 0$  of our system are invisible to our continuous approximation, as they make no contribution to the integrals. This is not surprising, seeing as the use of continuous approximation for a sum implicitly assumed that there were a small number of particles in each state. Our theory thus begins to break down for  $T \sim 0$  as we get a very significant fraction of particles occupying the groundstate. We thus must come up with another way of describing the system.

### Bose-Einstein Condensation

Recall that the first step when calculating quantitative for quantum gases was to calculate the chemical potential from the transcendental equation (3.39). For Bose gases, this is of the form

$$f(\beta\mu) = \frac{2}{\sqrt{\pi}} \int_0^\infty dx \frac{\sqrt{x}}{e^{x-\beta\mu} - 1} = \frac{n}{n_Q} \propto \frac{n}{T^{3/2}}$$

We have already found that we required  $\mu \leq 0$  for the occupation numbers to remain defined, and so we will only obtain a solution for this equation assuming that  $n/n_Q \leq f(0) = \zeta(3/2)$ , as shown in the following figure.

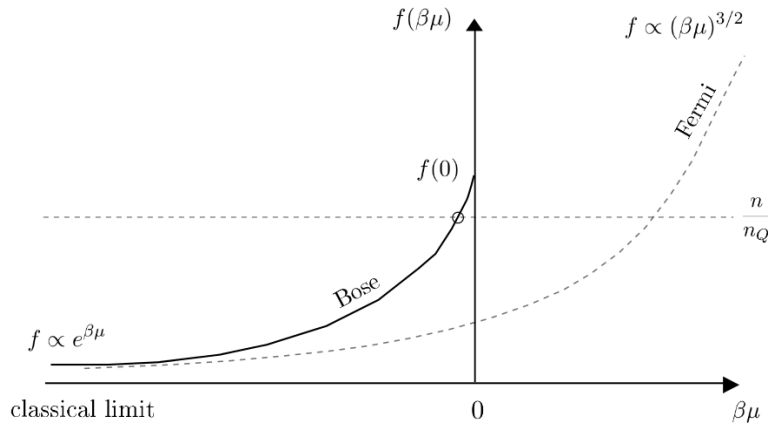

Figure 3.7: Determining  $N$  for a degenerate Bose gas

Evidently, there is only a solution to this equation if  $n/n_Q < f(0)$ . This means that there is some critical temperature  $T_c$  above which our original theory is valid; that is, some temperature that satisfies  $n/n_Q = f(0)$ . Then:

$$T_c = \frac{2\pi\hbar^2}{mk_B} \left[ \frac{n}{\zeta(3/2)(2s+1)} \right]^{3/2} \quad (3.48)$$

For all  $T < T_c$ , we thus set  $\mu = 0$ . This means that we can calculate the number of particles that are excited above the groundstate as

$$\frac{N}{Vn_Q} = f(0) \longrightarrow N_{\text{exc.}} = N \left( \frac{T}{T_c} \right)^{3/2}$$

Thus, the number of particles that remain in the groundstate is given by

$$\bar{n}_0 = N \left[ 1 - \left( \frac{T}{T_c} \right)^{3/2} \right] \quad (3.49)$$

This macroscopic occupation of the groundstate is known as *Bose-Einstein Condensation*. As  $T_c$  is very small, this effect can only really be observed at very low temperatures, and complete condensation can only occur at absolute zero. A figure showing the relevant occupation numbers can be found on the next page.

Astute readers may now be asking the question, what about the occupation number of the first excited state? Will that not be quite large as well, and change the behaviour of

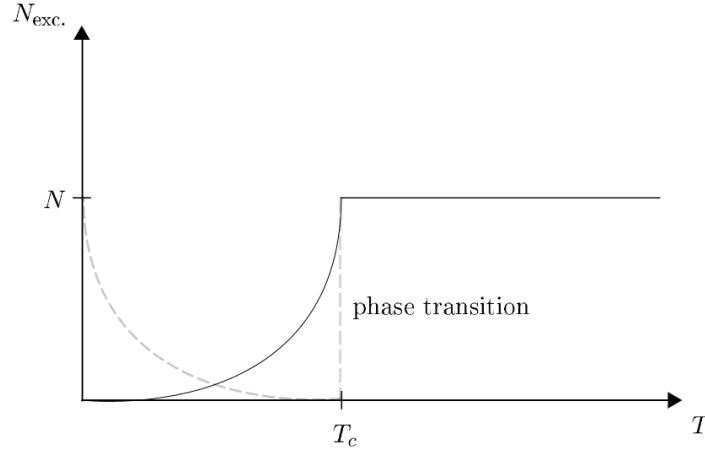

Figure 3.8: The number of particles in excited states in a degenerate Bose gas

the condensate? To answer this question, we first need to estimate the energy of the first excited state. The smallest possible wave-number allowed in our system of volume  $V$  is given by

$$k_{\min} = \frac{2\pi}{L} = \frac{2\pi}{V^{1/3}}$$

Using our classical expression for energy:

$$\varepsilon_1 = \frac{\hbar^2 k^2}{2m} = \frac{2\pi^2 \hbar^2 n^{2/3}}{m} \frac{1}{N^{2/3}} \sim \frac{k_B T_c}{N^{2/3}}$$

At low temperatures,  $1 \gg \beta\varepsilon_1 \gg \beta\mu$ . Using (3.36),

$$\bar{n}_1 \sim \frac{1}{e^{\beta\varepsilon_1} - 1} \sim \frac{1}{\beta\varepsilon_1} \propto N^{2/3}$$

This means that  $\bar{n}_1/\bar{n}_0 \sim 1/N^{1/3}$ . However, in the Thermodynamic limit,  $N \gg 1$ , meaning that this fraction is very small. As a result, we do not need to give special consideration to particles in the first excited state as a being a condensate, as they are only a small fraction in comparison to those in the groundstate.

*Show that Bose-Einstein condensation cannot occur in two dimensions.*

This example will demonstrate the significance of having a different density of states for the system; it can completely change the way it behaves. In two dimensions:

$$\sum_i = (2s+1) \sum_{\underline{k}} = (2s+1) \frac{A}{(2\pi)^2} \int d^2 \underline{k} = (2s+1) \frac{A}{2\pi} \int_0^\infty dk k$$

Using our classical expression for the energy, it is easy to show that the density of states is given by

$$g(\varepsilon) = \frac{(2s+1)Am}{2\pi\hbar^2}$$

Then, defining  $n_Q$  appropriately:

$$\frac{n}{n_Q} = \int_0^\infty dx \frac{1}{e^{x-\beta\mu} - 1} = \int_0^\infty dx \frac{e^{\beta\mu} e^{-x}}{1 - e^{-x} e^{\beta\mu}} = \log \left( \frac{1}{1 - e^{\beta\mu}} \right)$$

This means that it cannot form a condensate because there is no upper bound to  $n$ , meaning that the states of zero momentum can accommodate any  $n$ , resulting in no condensation. Putting it another way, there is no unique critical temperature  $T_c$  defined by this equation.

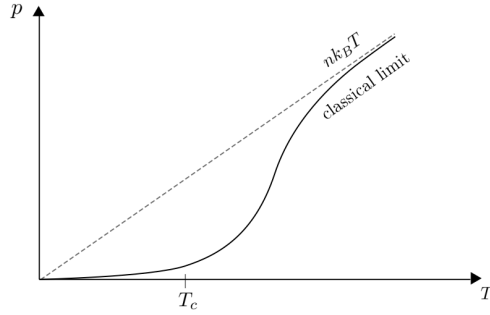

Figure 3.9: The pressure of a degenerate Bose gas

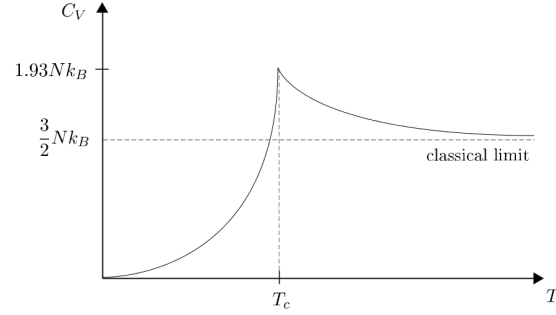

Figure 3.10: The heat capacity of a degenerate Bose gas

### Thermodynamic Quantities

Let us begin by calculating the mean energy of a degenerate Bose gas. Assuming  $T < T_c$ , we can set  $\mu = 0$ . Then

$$U = n_Q k_B T \underbrace{\frac{2}{\sqrt{\pi}} \int_0^\infty dx \frac{x^{3/2}}{e^x - 1}}_{\frac{3}{2} \zeta(\frac{5}{2})}$$

Writing this expression in terms of  $T_c$ , it becomes

$$U \sim 0.72 N k_B T_c \left( \frac{T}{T_c} \right)^{5/2} \quad (3.50)$$

Interestingly, we observe that this depends on both  $T$  and  $V$ , but not on the number of particles; this is hidden by the definition of  $T_c$ . Using (3.40), it very quickly follows that

$$p \sim 0.51 n k_B T_c \left( \frac{T}{T_c} \right)^{5/2} \quad (3.51)$$

This means that unlike with a degenerate Fermi gas, the pressure of a degenerate Bose gas is zero at  $T = 0$ . In fact, careful calculation reveals that this equation is asymptotic to the classical limit from below, as shown in the following figure above

Lastly, the heat capacity also follows very quickly from the definition of (3.50):

$$C_V \sim 1.93 N k_B \left( \frac{T}{T_c} \right)^{5/2} \quad (3.52)$$

We note that  $C_V$  is discontinuous around  $T = T_c$ , meaning that Bose-Einstein condensation represents a third order phase transition. Evidently, all of these quantities have been calculated assuming the non-relativistic case, but all that changes are the numerical factors, rather than the dependences on  $T_c$ .

*Consider bosons with spin 1 in a weak magnetic field, with energy levels*

$$\varepsilon(\underline{k}) = \frac{\hbar^2 k^2}{2m} - 2\mu_B s_z B \quad \text{for } s_z = -1, 0, 1$$

Find an expression for the magnetic susceptibility of the system  $\chi_m$  for small  $B$ , and examine the magnetisation of the system as  $B \rightarrow 0$ .

The easiest way to tackle this question is via the Grand Potential, and take derivatives to find  $\chi_m$ . Let  $\Phi$  be the Grand Potential of the system, and  $\Phi_0$  be the Grand Potential in the un-magnetised case. Writing the former in terms of the latter, we find that

$$\begin{aligned}\Phi &= \frac{1}{3}\Phi_0(\mu - 2\mu_B s_1 B) + \frac{1}{3}\Phi_0(\mu - 2\mu_B s_2 B) + \frac{1}{3}\Phi_0(\mu - 2\mu_B s_3 B) \\ &= \frac{1}{3}\Phi_0(\mu) + \frac{1}{3}\Phi(\mu - 2\mu_B B) + \frac{1}{3}\Phi_0(\mu + 2\mu_B B)\end{aligned}$$

Evidently, we obtain the trivial equality that  $\Phi = \Phi_0$  when we set  $B = 0$ , as expected. We can now Taylor expand this expression for small  $B$  to obtain:

$$\Phi \sim \underbrace{\Phi_0(\mu)}_{\text{indep. of } B} + \frac{1}{3}(2\mu_B B)^2 \frac{\partial^2 \Phi_0}{\partial \mu^2}$$

The magnetisation of the system is defined as

$$M = \frac{1}{V} \left( \frac{\partial \Phi}{\partial B} \right)_{T,V} = \frac{8\mu_B^2 B}{3} \frac{\partial^2 \Phi_0}{V \partial \mu^2} = -\frac{8\mu_B^2 B}{3} \frac{\partial \bar{N}}{V \partial \mu} \Big|_{T,V}$$

Calculating an expression for  $\bar{N}$  for a degenerate Bose gas for all  $T$ , and setting  $s = 1$ , we arrive at the expression

$$\chi_m = \left( \frac{\partial M}{\partial B} \right)_{T,V} = \frac{8\mu_B^2}{\lambda_{th}^3} \frac{2}{\sqrt{\pi}} \frac{\partial}{\partial \mu} \left( \int_0^\infty dx \frac{\sqrt{x}}{e^{x-\beta\mu} - 1} \right)$$

In the classical limit,  $e^{\beta\mu} \sim n\lambda_{th}^3 \ll 1$ , and so

$$\int_0^\infty dx \frac{\sqrt{x}}{e^{x-\beta\mu} - 1} \sim e^{\beta\mu} \int_0^\infty dx \sqrt{x} e^{-x} = e^{\beta\mu} \frac{\sqrt{\pi}}{2}$$

Substituting this into the expression for  $\chi_m$ , we find that the magnetic susceptibility reduces to Curie's Law in the classical limit, as it should. In the other limit as  $T \rightarrow T_c^+$ ,  $\beta\mu \rightarrow 0$ , and the integral in our expression for  $\chi_m$  does not converge. This means that the system must have infinite magnetic susceptibility at  $T = T_c$ .

For  $T < T_c$ , the gas will form a condensate, meaning that the groundstate occupation number is given by (3.49). Then, to a very good approximation, the magnetisation will be given by

$$M_0 = \frac{2\mu_B \bar{n}_0}{V} = 2\mu_B n \left[ 1 - \left( \frac{T}{T_c} \right)^{3/2} \right]$$

Evidently, for  $B = 0$ , there is no magnetisation, as the spins are sufficiently randomly distributed that they do not produce a net magnetisation in the material. However, as soon as  $B$  is non-zero, this makes a particular alignment energetically favourable, and so all the particles in the groundstate will align as such. This means that there will be a large magnetisation even for  $B \rightarrow 0^+$ .

### 3.6 The Photon Gas

Thermal radiation can be modelled as a gas of photons with energy per particle  $\hbar\omega$ , with chemical potential  $\mu = 0$ , and which has an energy density profile that is only dependent on temperature (black body radiation). It follows that for a gas of  $N$  particles that the energy density is given by

$$u = u(T) = n\hbar\omega$$

From Kinetic Theory, we know that the particle flux is  $\Phi = nc/4$ , meaning that the energy flux is given by  $P = uc/4$ . Lastly, by analogy to (2.8), we can write the pressure of the photon as  $p = u/3$ . With this set-up, let us derive some further properties of the gas from both Thermodynamics, and the theory of Quantum Gases.

#### 3.6.1 Thermodynamically

Starting from (3.17), it quickly follows that for a gas with the above properties

$$dU = TdS - \frac{u}{3}dV \longrightarrow \left(\frac{\partial U}{\partial V}\right)_T = T \left(\frac{\partial S}{\partial V}\right)_T - \frac{u}{3}$$

However, we know that

$$\left(\frac{\partial U}{\partial V}\right)_T = \frac{\partial}{\partial V}(uV)_T = u + V \left(\frac{\partial u}{\partial V}\right)_T = u$$

as  $u$  cannot depend on the size of the system by the definition of energy density. Recalling (1.31):

$$\left(\frac{\partial S}{\partial V}\right)_T = \left(\frac{\partial p}{\partial T}\right)_V = \frac{1}{3} \frac{du}{dT}$$

We thus obtain the differential equation

$$u = \frac{1}{3}T \frac{du}{dT} - \frac{u}{3} \longrightarrow 4u = T \frac{du}{dT}$$

that we can solve to obtain  $u \propto T^4$ . This means that *incident power per unit area* is given by

$$\boxed{P = \frac{1}{4}uc = \sigma T^4} \quad (3.53)$$

for some constant of proportionality  $\sigma$  that is known as the *Stefan-Boltzmann constant*. However, to find the actual value of the constant, we have to treat the photon gas using the theory of Section (3.5).

#### 3.6.2 As a Quantum Gas

Photons are bosons, where their spin can take the values  $s = \pm 1$ . We want to calculate the number density of photons with frequencies in the range  $[\omega, \omega + d\omega]$ . The density of states for such a system is given by

$$g(k) dk = \underbrace{2}_{\text{polarisation states}} \frac{V}{(2\pi)^3} 4\pi k^2 dk = \frac{V k^2}{\pi^2} dk$$

Using the dispersion relation  $\omega = ck$ , this can be written as

$$g(\omega) d\omega = \frac{V}{\pi^2 c^3} \omega^2 d\omega$$

Assuming that there are a large enough number of photons to approximate them as having a continuous spectrum, we can use (3.36) with  $\mu = 0$  and  $\varepsilon = \hbar\omega$  to write that

$$n_i = \frac{1}{e^{\beta\hbar\omega} - 1}$$

Thus, the number density of the photons is given by

$$n(\omega) = \frac{1}{\pi^2 c^3} \frac{\omega^2}{e^{\beta\hbar\omega} - 1}$$

This means that the *spectral energy density* is given by

$$\boxed{u_\omega(\omega) = \frac{\hbar}{\pi^2 c^3} \frac{\omega^3}{e^{\beta\hbar\omega} - 1}} \quad (3.54)$$

When integrated, this will give the energy density of the photon gas. We can use this to find an expression for the Stefan-Boltzmann constant:

$$u = \int d\omega u_\omega(\omega) = \frac{\hbar}{\pi^2 c^3} \int_0^\infty d\omega \frac{\omega^3}{e^{\beta\hbar\omega} - 1} = \frac{\hbar}{\pi^2 c^3} \frac{1}{(\hbar\beta)^4} \underbrace{\int_0^\infty dx \frac{x^3}{e^x - 1}}_{\pi^4/15}$$

where we have made the substitution  $x = \beta\hbar\omega$ . By comparison with (3.53), it is clear that the Stefan Boltzmann can be expressed as

$$\boxed{\sigma = \frac{\pi^2 k_B^4}{60 \hbar^3 c^2} = 5.67 \times 10^{-8} \text{ W m}^{-2} \text{K}^{-4}} \quad (3.55)$$

By letting  $\omega = (2\pi c)/\lambda$ , we can also write the spectral energy density in the form

$$u_\lambda(\lambda) = \frac{8\pi hc}{\lambda^5} \frac{1}{e^{\beta hc/\lambda} - 1} \quad (3.56)$$

In the classical limit,  $\beta$  becomes very small, so we can Taylor expand, yielding the *Rayleigh-Jeans law*:

$$u_\lambda(\lambda) = \frac{8\pi k_B T}{\lambda^4}$$

This evidently diverges for low  $\lambda$ , giving infinite energy density, which is known as the *ultraviolet catastrophe*. We thus need the quantisation that is implicitly included in (3.56). This distribution has a maximum that can be found numerically as  $\lambda_{\max} \sim (hc)/(5k_B T)$ . This gives rise to *Wien's Law* which states that

$$\boxed{\lambda_{\max} T = \text{constant}} \quad (3.57)$$

That is, the product of the maximum wavelength emitted by a black-body and its temperature will yield a constant value. This can be used to find the temperature of stars, for example.

## 4. *Further Thermodynamics*

This chapter aims to extend the readers knowledge of Thermodynamics, covering

- Real Gases
- Phase Transitions

This quite short chapter builds on the ideas outlined in the first three chapters to look at some more accurate descriptions of gas behaviour, as well as look at some further concepts about phase transitions between solids, liquids and gases. As is often the case with Thermodynamics, it is not particularly complicated, just time consuming to learn!

## 4.1 Real Gases

For most of the Thermodynamics that we have been doing with gases, we have merely dealt with the Ideal Gas, as this is the simplest way to model gases. However, evidently most gases are non-ideal, and so it would be useful to develop other ways of describing the behaviour of gases, as we will do so in the following sections. Before we do so, let us derive a useful result for the energy of a gas. Consider  $U = U(T, V)$ :

$$dU = \left(\frac{\partial U}{\partial T}\right)_V dT + \left(\frac{\partial U}{\partial V}\right)_T dV$$

From (3.17), assuming a closed system ( $dN = 0$ ):

$$\left(\frac{\partial U}{\partial V}\right)_T = T \left(\frac{\partial S}{\partial V}\right)_T - p = T \left(\frac{\partial p}{\partial T}\right)_V - p$$

where we have made use of (1.31). Putting these together, this gives

$$\boxed{dU = C_V dT + \left[T \left(\frac{\partial p}{\partial T}\right)_V - p\right] dV} \quad (4.1)$$

This can be used to show, for example, that  $U$  is only a function of temperature for certain gases (the second term is zero for an ideal gas, and certain other equations of state). It is also a relation that one is commonly asked to derive, so it is well worth having in the memory bank.

Let us also recap some important notation. We will use  $n_m = N/N_A$  to refer to the number of moles of a substance. Recall the gas constant  $R = N_A k_B$ . This means that we can write the simple relation

$$Nk_B = n_m R \quad (4.2)$$

that allows us to convert between (typically) Statistical Mechanics and Kinetic Theory expressions (involving  $k_B$ ), and Thermodynamic expressions (involving  $R$ ), though they are of course equivalent.

### 4.1.1 Virial Expansion

The equations describing real gases include some corrections for the fact that intermolecular forces, that we have neglected with the Ideal Gas, exist. This often means that they will reduce to the case of the Ideal Gas in some limit, and so we can write them as a *virial expansion* in their density:

$$\boxed{\frac{pV}{n_m RT} = 1 + \frac{n_m B}{V} + \frac{n_m^2 C}{V^2} + \dots} \quad (4.3)$$

where  $B$  and  $C$  are the (possibly) temperature dependent coefficients, and  $n_m$  is the number of moles of the gas.

The *Boyle temperature* is defined as the temperature that satisfies  $B(T_b) = 0$ ; that is, the temperature that means that the gas behaves like an ideal gas to first order in  $n_m$ . It is so called because it will thus obey Boyle's empirical law.

### 4.1.2 Van-der-Waals Gas

This is the one of the most common real gas approximations. The equation of state can be derived through a Statistical Mechanics approach by making a mean-field approximation, but it is much easier to quote the equation and explain the origin of the various terms. The *Van-der-Waals* equation of state is as follows:

$$\boxed{\left(p + \frac{a n_m^2}{V^2}\right)(V - b n_m) = n_m RT} \quad (4.4)$$

where  $a$  and  $b$  are coefficients that depend on the nature of the gas being examined. This has been written in molar form as this allows easier comparison with (4.3), but it can also be written in terms of particle number  $N$ . There are some key features to note:

- The number of nearest neighbours to a particular particle is proportional to  $n_m/V$ , and so attractive intermolecular interactions lower the total potential energy by an amount proportional the number of atoms multiplied by the number of nearest neighbours. This means that we can write the potential change as  $(a n_m)/V$  which gives rise to an energy change  $-(a n_m^2 dV)/V^2$ . This can be thought of as an effective pressure causing the energy change, giving rise to the extra term shown
- The term  $b n_m$  comes from considering the particles to have a finite size (instead of point particles), meaning that we must exclude this volume in the equation of state

It is evident that this equation reduces to the Ideal Gas equation in the low density limit  $n_m/V \ll 1$ . It is also under this limit that we can write this equation as a virial expansion:

$$\frac{pV}{n_m RT} = \left(1 - \frac{b n_m}{V}\right)^{-1} - \frac{a n_m}{RTV} \sim 1 + \left(b - \frac{a}{RT}\right) \frac{n_m}{V} + \left(\frac{b n_m}{V}\right)^2 + \dots$$

This means that the Boyle temperature for a Van der Waals gas is  $T_b = a/(bR)$ .

### 4.1.3 Dieterici Gas

An alternative equation of state is that of the *Dieterici gas*, which is as follows:

$$\boxed{p(V - b n_m) = n_m RT \exp\left(-\frac{a n_m}{RTV}\right)} \quad (4.5)$$

Once again, the  $b n_m$  comes from the requirement of excluding the finite volume of the particles from the calculation, and the exponential term regulates the strength of the inter-particle interaction. This description of real gases can prove more accurate than that of the Van der Waals model, but not by a significant margin. Once again, this can also be written as a virial expansion in the low density limit:

$$\frac{pV}{n_m RT} = \frac{e^{-(a n_m)/(RTV)}}{1 - (b n_m)/V} \sim 1 + \left(b - \frac{a}{RT}\right) \frac{n_m}{V} + \left(b^2 + \frac{a^2}{2R^2 T^2} - \frac{ab}{RT}\right) \left(\frac{n_m}{V}\right)^2 + \dots$$

This means that the Boyle temperature for a Dieterici gas is actually the same as that of the Van der Waals gas.

### 4.1.4 Critical Points

In Thermodynamics, *phases* are *regions of a system throughout which all physical properties of a material are essentially uniform*; this is often used to refer to different states of a particular substance that exist within the one system, such as a 'liquid phase' and 'gas

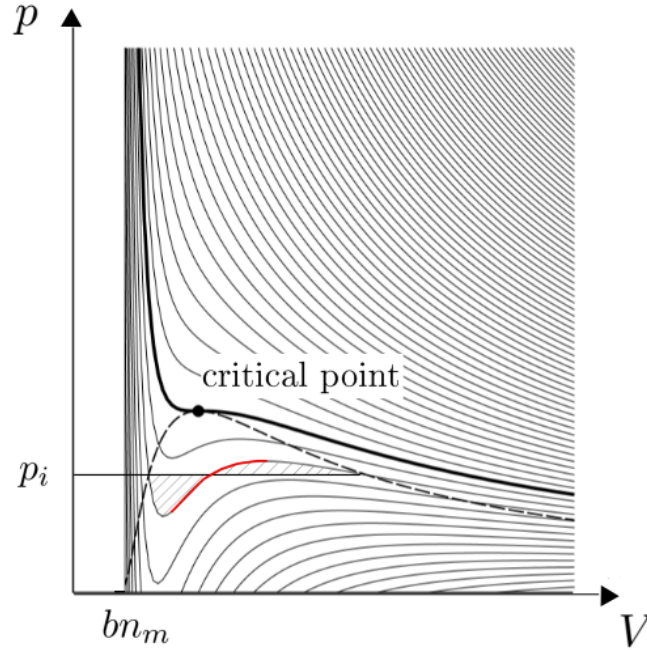

Figure 4.1: Isotherms of the Van der Waals gas (temperature increasing towards the top right), with dashed liquid-vapour equilibrium curve, critical isotherm and critical point

phase'. With that in mind, consider the isotherms (lines of constant temperature) for the Van der Waals gas. These are plotted in the figure above.

We remark how for a particular range of values of pressure (for a given isotherm), that there are two possible values of volume that we shall call  $V_1$  and  $V_2$ . For a given pressure  $p_i$ , the two phases associated with these different volumes are in equilibrium. We know from Sections (3.2.2) and (3.3.1) that can only have equilibrium when temperature, pressure and chemical potential are equal in both phases. As we know that the pressure and the temperature are both equal (we are sitting on an isotherm at a given pressure), the condition for these phases being in equilibrium must then be

$$\int_1^2 d\mu = \int_1^2 V dp = 0 \quad (4.6)$$

That is, the shaded areas under the curves must be equal. Note that the first equality follows from the results of the next section. The region of the curve marked in red in the diagram represents a region of instability; here, the isothermal compressibility  $\kappa_T = -\frac{1}{V} \left( \frac{\partial V}{\partial p} \right)_T$  is negative, meaning that the more pressure you apply, the more the gas is allowed to expand. This means that phase transitions that occur between our two volumes  $V_1$  and  $V_2$  tend to be very 'sharp'.

Now, there is a particular *critical point* for which there is no point of inflexion. This means that the two phases can no longer co-exist in equilibrium, and one dominates (usually the gas). This causes the equilibrium curve in the  $p$ - $T$  plane to terminate at this critical point, meaning that we can actually avoid 'sharp' phase transitions by going 'around' this point.

We can characterise a critical point by a pressure  $p_c$ , temperature  $T_c$  and volume  $V_c$ . As a critical point is a point of inflexion by definition, we can find it by applying

$$\boxed{\left(\frac{\partial p}{\partial V}\right)_T = 0 \quad \text{and} \quad \left(\frac{\partial^2 p}{\partial V^2}\right)_T = 0} \quad (4.7)$$

in conjunction with the equation of state of the gas to solve for these three unknowns. We can then use these 'critical coordinates' to define the *compressibility factor*

$$Z = \frac{p_c V_c}{n k_B T_c}$$

This leads to what is known as the *Law of Corresponding States*; that many different gases all have the same compressibility factor. We then define *reduced coordinates*  $\tilde{p} = p/p_c$ ,  $\tilde{V} = V/V_c$  and  $\tilde{T} = T/T_c$ . Writing the equation of state in terms of these reduced coordinates, according to the law of corresponding states, should give the same equation regardless of the gas, with only the critical units changing from gas to gas.

*Find the critical point coordinates for the Dieterici equation of state, and write it in reduced coordinates.*

We can re-arrange (4.5) to give

$$p = \frac{n_m R T}{V - b n_m} e^{-(a n_m)/(R T V)}$$

Performing the differentiation:

$$\left(\frac{\partial p}{\partial V}\right)_T = 0 \rightarrow \frac{V^2}{V - b n_m} = \frac{a n_m}{R T}$$

Defining  $u = V/(b n_m)$ , we can write

$$f(u) = \frac{u^2}{u - 1} = \frac{a}{b R T}$$

Applying the second derivative condition ( $f'(u) = 0$ ), we find that  $u = 2 \rightarrow V_c = 2 b n_m$ . Then, it is just a few simple steps of algebra to show that

$$T_c = \frac{a}{4 b R} \quad \text{and} \quad p_c = \frac{a}{4 e^2 b^2}$$

Writing  $T = \tilde{T} T_c$ , and similarly for  $p$  and  $V$ , it is again a step of relatively simple algebra to show that

$$\tilde{p}(2\tilde{V} - 1) = \tilde{T} \exp \left[ 2 \left( 1 - \frac{1}{\tilde{T}\tilde{V}} \right) \right]$$

#### 4.1.5 Expansions of Real Gases

We can use the results derived in the previous sections to now look at some of the deviations from Ideal Gas behaviour that can be observed in practise; this often involves the expansion of gases. We shall look at two expansions in particular.

### The Joule Expansion

We have already met this expansion in Section (1.4.5). To recap, this involves two chambers with adiabatic walls, so no heat is exchanged with the surroundings - the gas is allowed to expand freely when the piston is drawn back, so no work is done. The change in internal energy is therefore zero. We are thus interested in whether this results in a change in temperature, and so we define the *Joule coefficient*  $\mu_J$  as

$$\mu_J = \left( \frac{\partial T}{\partial V} \right)_U = - \left( \frac{\partial T}{\partial U} \right)_V \left( \frac{\partial U}{\partial V} \right)_T = - \frac{1}{C_V} \left[ T \left( \frac{\partial S}{\partial V} \right)_T - p \right]$$

Making use of (1.31), this becomes

$$\boxed{\mu_J = - \frac{1}{C_V} \left[ T \left( \frac{\partial p}{\partial T} \right)_V - p \right]} \quad (4.8)$$

We can find the change in temperature by the simple integration of this coefficient over the change in volume. As we have seen,  $\mu_J = 0$  for an Ideal Gas, meaning that we observe no change in temperature. However, for a Van der Waals gas, we find that  $\mu_J = -(an_m^2)/(C_V V^2)$ , meaning that there is in fact cooling of the gas upon expansion. This we would expect, as for real gases the potential energy is raised by forcing the molecules apart against intermolecular forces upon expansion, which lowers the kinetic energy, and thus temperature.

### The Joule-Kelvin Expansion

The Joule-Kelvin expansion involves the steady flow of gas through a porous plug that imposes the condition of quasi-stasis. The gradient between the two chambers, as well as the rate of flow, are kept constant using pistons. The chambers once again have adiabatic walls, and so there is no heat exchange with the surroundings.

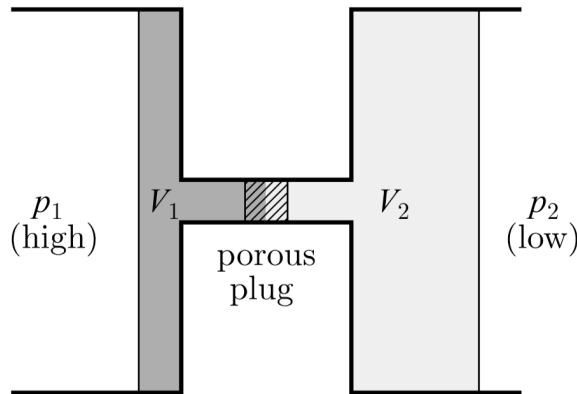

Figure 4.2: A schematic of the Joule-Kelvin Expansion

Suppose that after some time, the gas occupies a volume  $V_1$  in the higher pressure chamber, and a volume  $V_2$  in the lower pressure. This means that we can write the energy change as

$$U_2 - U_1 = \underbrace{p_1 V_1}_{\text{work done by } p_1} - \underbrace{p_2 V_2}_{\text{work against } p_2} \longrightarrow \underbrace{U_1 + p_1 V_1}_{H_1} = \underbrace{U_2 + p_2 V_2}_{H_2}$$

It is clear that the the enthalpy  $H$  is conserved in the process. This means that we are interested in temperature changes at constant  $H$ . We thus define (you guessed it), the *Joule-Kelvin coefficient*

$$\mu_{JK} = \left( \frac{\partial T}{\partial p} \right)_H = - \left( \frac{\partial T}{\partial H} \right)_p \left( \frac{\partial H}{\partial p} \right)_T$$

Recalling that  $dH = TdS + Vdp$ , we have that

$$\left( \frac{\partial H}{\partial T} \right)_p = T \left( \frac{\partial S}{\partial T} \right)_p = C_p \quad \text{and} \quad \left( \frac{\partial H}{\partial p} \right)_T = T \left( \frac{\partial S}{\partial p} \right)_T + V$$

Putting this together, we can write the Joule-Kelvin coefficient as

$$\boxed{\mu_{JK} = \frac{1}{C_p} \left[ T \left( \frac{\partial V}{\partial T} \right)_p - V \right]} \quad (4.9)$$

We can thus find the change in temperature by integrating  $\mu_{JK}$  over the change in pressure. This is evidently again zero for the ideal gas. However, for real gases,  $\mu_{JK}$  can either be positive (cooling) or negative (heating), meaning that we have a cross-over *inversion curve* that is defined by the equation  $\mu_{JK} = 0$ , or rather

$$\left( \frac{\partial V}{\partial T} \right)_p = \frac{V}{T}$$

Using the reciprocity relation (1.22), this can be written in the more convenient form

$$\boxed{T \left( \frac{\partial p}{\partial T} \right)_V + V \left( \frac{\partial p}{\partial V} \right)_T = 0} \quad (4.10)$$

From this, we can also define the *maximum inversion temperature* below which the Joule-Kelvin process results in cooling.

## 4.2 Phase Transitions and Equilibria

We are now going to look at the details of *phase transitions*; that is, the Thermodynamic processes where-by a substance changes from one phase to another. A very typical example is that of the boiling of water; the phase transition is quite rapid, as it is only when the boiling point is reached that the liquid phase becomes thermodynamically unstable, and the gas phase thermodynamically stable.

### 4.2.1 Latent Heat

Usually to change from one phase, at entropy  $S_1$ , to another phase at entropy  $S_2$ , we require some additional heat supply. This is known as the *latent heat* (of evaporation, melting, etc.) given by

$$\boxed{L = \Delta Q_{rev} = T(S_2 - S_1)} \quad (4.11)$$

where  $T$  is used to refer to the temperature at which the phase transition occurs; the change in entropy occurs instantaneously at this temperature. As we are interested in changes at constant temperature, we will be making use of the Gibbs Free Energy.

Ehrenfest's method of classifying phase transitions is that the *order* of a phase transition is the order of the derivative of  $G$  or  $\mu$  that is discontinuous. First-order phase transitions have discontinuous entropy and volume, and so they exhibit a latent heat. Second-order phase transitions have no latent heat but may have discontinuous heat capacities or compressibility ( $2^{nd}$  derivatives of  $G$ ). When no latent heat is exhibited (continuous entropy), we have a continuous phase change. In Van der Waals gas, we can have either continuous or discontinuous phase changes depending on whether we go 'directly across' the phase boundary or around the critical point, as outlined in Section (4.1.4).

### 4.2.2 The Clausius-Clapeyron Equation

Recall from (3.18) that  $G = \mu N$ . This means that we obtain the two differential forms for  $G$ :

$$dG = Vdp - SdT \quad \text{and} \quad dG = \mu dN + Nd\mu$$

Assuming that total particle number is conserved, we find that the differential form of  $\mu$  can be written as

$$d\mu = -\frac{S}{N}dT + \frac{V}{N}dp = -sdT + vdp$$

where  $s$  and  $v$  are the entropy per particle and volume per particle respectively. From Section (3.3.1), we know that  $\mu_1 = \mu_2$  for the phases to coexist in equilibrium, and so we know that along the  $p$ - $T$  boundary for the two phases

$$\begin{aligned} d\mu_1 &= d\mu_2 \\ -s_1 + v_1 \frac{dp}{dT} &= -s_2 + v_2 \frac{dp}{dT} \\ \frac{dp}{dT} &= \frac{s_1 - s_2}{v_1 - v_2} \end{aligned}$$

Substituting in our expression for latent heat, we obtain the *Clausius-Clapeyron equation*

$$\boxed{\frac{dp}{dT} = \frac{L}{T(V_2 - V_1)}} \quad (4.12)$$

Depending on the type of transition, we can use this to derive different  $p$ - $T$  curves for the phase boundaries.

### Solid-Liquid Boundary

The Clausius-Clapeyron equation can be simply re-arranged to give

$$dp = \frac{LdT}{T\Delta V}$$

where  $\Delta V = V_2 - V_1$ . Assuming that both  $\Delta V$  and  $L$  are temperature independent, then this equation can be integrated to yield

$$\boxed{p = p_0 + \frac{L}{\Delta V} \log\left(\frac{T}{T_0}\right)} \quad (4.13)$$

The constants  $p_0$  and  $T_0$  are chosen such that  $p = p_0$  and  $T = T_0$  on the boundary. The volume change  $\Delta V$  on melting is relatively small, so that the gradient of the phase boundary in the  $p$ - $T$  plane is very steep.

*When lead is melted at atmospheric pressure the melting point is  $327.0^\circ\text{C}$ , the density decreases from  $11.01 \times 10^3$  to  $10.65 \times 10^3 \text{ kg m}^3$  and the latent heat is  $24.5 \text{ kJ kg}^{-1}$ . Estimate the melting point of lead at a pressure of 100 atm.*

We can use the above equation to write that

$$\Delta p = \frac{L}{\Delta V} \log\left(\frac{T_2}{T_1}\right) \rightarrow T_2 = T_1 e^{\frac{\Delta p \Delta V}{L}}$$

We are already given that  $\Delta p = 99 \text{ atm}$ . Suppose that there is a mass  $M$  of lead. Then the change in the specific volume (volume per unit mass) is given by

$$\Delta V = v_{\text{liquid}} - v_{\text{solid}} = \frac{1}{\rho_{\text{liquid}}} - \frac{1}{\rho_{\text{solid}}} \sim 3.07 \times 10^{-6} \text{ m}^3 \text{ kg}^{-1}$$

Recalling that  $L$  is a specific, per unit mass quantity, we can then simply plug everything into our expression for  $T_2$  yielding  $\sim 327.75^\circ\text{C}$ , which is a very small change in temperature.

### Liquid-Gas Boundary

Let us initially treat this boundary assuming that  $V_{\text{gas}} = V \gg V_{\text{liquid}}$ , the resultant gas is ideal, and  $L$  is temperature independent. The former of these assumptions is not particularly assumptive, as most incompressible fluids undergo a large expansion when moving to their gaseous phase. Then, according to the Clausius-Clapeyron equation:

$$\frac{dp}{dT} = \frac{L}{TV} = \frac{pL}{n_m RT^2}$$

where we have used the ideal gas equation in the second equality. This equation can be integrated to give

$$\boxed{p = p_0 \exp\left(-\frac{L}{n_m RT}\right)} \quad (4.14)$$

As  $R = N_A k_B$ , the exponential factor is roughly Boltzmann. This equation can be used to solve that annoyingly typical example about boiling a cup of tea on the top of a mountain; it is evident that the British simply cannot get away from their tea.

Suppose now that we do not make any assumptions about the temperature dependence of latent heat. At the phase boundary, we can write that  $\Delta S = L/T$ . Noting that we can write the total derivative with respect to temperature as

$$\frac{d}{dT} = \left( \frac{\partial}{\partial T} \right)_p + \frac{dp}{dT} \left( \frac{\partial}{\partial p} \right)_T$$

we can find the change in  $\Delta S$  as

$$\begin{aligned} \frac{d}{dT} \left( \frac{L}{T} \right) &= \left( \frac{\partial \Delta S}{\partial T} \right)_p + \frac{dp}{dT} \left( \frac{\partial \Delta S}{\partial p} \right)_T \\ \frac{1}{T} \frac{dL}{dT} - \frac{L}{T^2} &= \frac{\Delta C_p}{T} + \frac{dp}{dT} \left[ \left( \frac{\partial S_g}{\partial p} \right)_T - \left( \frac{\partial S_\ell}{\partial p} \right)_T \right] \\ \frac{dL}{dT} &= \frac{L}{T} + \Delta C_p - T \frac{dp}{dT} \left[ \frac{\partial}{\partial T} (V_g - V_\ell)_p \right] \end{aligned}$$

where the subscripts  $\ell$  and  $g$  are used to refer to the liquid and the gas respectively, and  $\Delta C_p = C_{pg} - C_{p\ell}$ . Using the assumption about the relative volumes of the liquid and the gas, and substituting the Clausius-Clapeyron equation, we find that

$$\frac{dL}{dT} = \frac{L}{T} + \Delta C_p - \frac{L}{V_g} \left( \frac{\partial V_g}{\partial T} \right)_p$$

Assuming that the gas produced is ideal, then this equation simplifies to

$$\frac{dL}{dT} = \Delta C_p \longrightarrow L = L_0 + \Delta C_p T$$

Substituting this result back into the Clausius-Clapeyron equation, and solving, yields:

$$\boxed{p = p_0 \exp \left( -\frac{L_0}{n_m R T} + \frac{\Delta C_p \log(T)}{n_m R} \right)} \quad (4.15)$$

### $p$ - $T$ Curves

We are now going to consider a short example to illustrate how to think about phase transitions with respect to  $p$ - $T$  curves. Suppose that a saturated gas expands adiabatically. What is the condition on the gradient of the  $p$ - $T$  curve for some gas to condense? Looking at the figure on the right, it is clear that the gas has to 'cross' the transition curve with gradient  $dp/dT$  in order to condense. This means that when moving left (lower pressure and temperature associated with expansion) along the adiabatic curve, we need to be able to cross the transition curve. From this, it is clear that the condition on the gradients of the two curves is

$$\left( \frac{\partial p}{\partial S} \right)_S < \frac{dp}{dT}$$

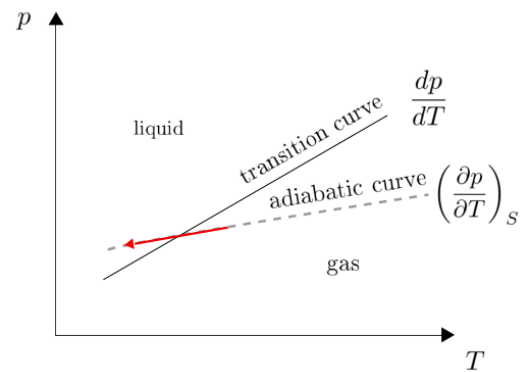

Figure 4.3: The adiabatic compression of a gas